

An Example of Two-Dimensional Interpolation Using a Linear Combination of Bicubic B-Splines

Stanisław Rosłonec

Abstract—The paper describes how a linear combination of bicubic B-splines can be effectively used in a two-dimensional interpolation. It is assumed that values of a function to be interpolated are evaluated at the uniformly located nodes of a corresponding rectangular grid. All formulae of importance have been derived step by step and are presented in a form convenient for computer implementations. To ensure clarity of considerations a short description of one-dimensional B-spline is also given in Appendix 1. The usefulness of the presented interpolation algorithm has been confirmed by the real engineering example of applications.

Keywords—Numerical analysis, two-variable interpolation, cubic B-splines.

I. INTRODUCTION

At the present time the most of science and engineering problems are analysed numerically. Consequently the results of calculations are presented in a form of tables or the corresponding parametrical diagrams. It is obvious that these traditional forms of presentation are rather inconvenient for computer-aided design (CAD), calibration of electronic system or automatic control [1]–[4]. Thus, in such situations the proper interpolation or approximation of final numerical results by the continuous and differentiable functions are required. Of course, the used functions should be also smooth enough and the interpolation method should not be excessively complex. It follows from the relevant literature that the normalised bicubic B-splines seem to be the most suitable for this purpose, especially when the interpolation problem being solved is large in size, [5]–[7]. Therefore, in the present paper it is shown how the interpolation problem formulated above can be effectively solved by using the bicubic B-splines. The proposed approach is illustrated with results of calculations carried out for a shielded coaxial slab transmission line.

II. THE ALGORITHM OF TWO-DIMENSIONAL INTERPOLATION USING CUBIC B-SPLINES

The problem of interpolation of a one-variable function by the linear combination of the cubic B-splines is a subject of considerations in many publications, see [5] and [7] for instance. As a rule the interpolating function has the form

$$Q_1(x) = \sum_{i=-1}^{m+1} a_i B^{(i)}(x), \quad x_0 \leq x \leq x_m \quad (1)$$

This analytical one-variable function can be easily converted into the two-variable one by assuming that all its coefficients

a_i , namely $a_{-1}, a_0, a_1, a_2, a_3, \dots, a_{m+1}$ are similar functions of the second variable, i.e.

$$a_i \equiv a_i(y) = \sum_{j=-1}^{n+1} a_{i,j} B^{(j)}(y), \quad y_0 \leq y \leq y_n \quad (2)$$

where $a_{i,-1}, a_{i,0}, a_{i,1}, a_{i,2}, a_{i,3}, \dots, a_{i,n+1}$ are new real-valued coefficients creating $(n+3)$ -element vectors \mathbf{a}_i for $-1 \leq i \leq m+1$. Also in this case $B^{(j)}(y)$ denotes the cubic B-spline related to its central node $y = y_j$, see the Appendix 1. After introducing coefficients (2) into function (1) we obtain:

$$\begin{aligned} Q_2(x, y) &= \sum_{i=-1}^{m+1} \left[\sum_{j=-1}^{n+1} a_{i,j} B^{(j)}(y) \right] B^{(i)}(x) = \\ &= B^{(-1)}(x) [a_{-1,-1} B^{(-1)}(y) + a_{-1,0} B^{(0)}(y) + a_{-1,1} B^{(1)}(y) + \\ &\quad \dots + a_{-1,n+1} B^{(n+1)}(y)] + B^{(0)}(x) [a_{0,-1} B^{(-1)}(y) + \\ &\quad + a_{0,0} B^{(0)}(y) + a_{0,1} B^{(1)}(y) + \dots + a_{0,n+1} B^{(n+1)}(y)] + \\ &\quad \dots \\ &\quad + B^{(m+1)}(x) [a_{m+1,-1} B^{(-1)}(y) + a_{m+1,0} B^{(0)}(y) + \\ &\quad + a_{m+1,1} B^{(1)}(y) + \dots + a_{m+1,n+1} B^{(n+1)}(y)] \quad (3) \end{aligned}$$

The two-variable function formulated above, includes $(m+3)(n+3)$ independent coefficients $a_{i,j}$ because B-spline functions of third degree are defined for $-1 \leq i \leq m+1$ and $-1 \leq j \leq n+1$. In order to evaluate the values of

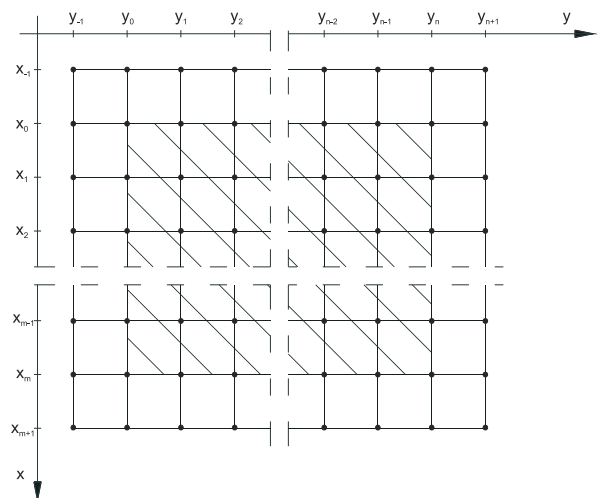

Fig. 1. The extended interpolation region including additional (fictitious) nodes.

these coefficients a system of $(m + 3)(n + 3)$ independent equations has to be created. For this purpose the given values $z_{i,j}$ of the function to be interpolated, determined at particular nodes (x_i, y_j) of the doubly regular grid, are used, see Fig.1. There the term “doubly regular grids” means that its nodes are distributed equidistantly with step h_x with respect to variable x and with step h_y with respect to the second variable y . Due to this assumption the B-spline functions $B^{(i)}(x)$ and $B^{(j)}(y)$ can be calculated without difficulty by using the formulae (18) given in Appendix 1. On the grid shown in Fig.1, we can separate $(m + 1)(n + 1)$ nodes of the proper interpolation region $R : \{(x, y), x_0 \leq x \leq x_m, y_0 \leq y \leq y_n\}$ (dashed) and $2(m+n)+8$ additional (fictitious) nodes surrounding this region.

Function (3) should interpolate exactly the given discrete function $z_{i,j}$ at all nodes (x_i, y_j) of a doubly regular grid defined on the interpolation region R . This fundamental requirement is satisfied if

$$Q_2(x_k, y_l) = \sum_{i=-1}^{m+1} \left[\sum_{j=-1}^{n+1} a_{i,j} B^{(j)}(y_l) \right] B^{(i)}(x_k) = z_{k,l} \quad (4)$$

where $0 \leq k \leq m$ and $0 \leq l \leq n$. The complete form of the above equation is:

$$\begin{aligned} &B^{(-1)}(x_k)[a_{-1,-1}B^{(-1)}(y_l)+a_{-1,0}B^{(0)}(y_l)+a_{-1,1}B^{(1)}(y_l)+ \\ &\dots + a_{-1,n+1}B^{(n+1)}(y_l)] + B^{(0)}(x_k)[a_{0,-1}B^{(-1)}(y_l)+ \\ &+a_{0,0}B^{(0)}(y_l) + a_{0,1}B^{(1)}(y_l) + \dots + a_{0,n+1}B^{(n+1)}(y_l)]+ \\ &\dots \\ &+B^{(m+1)}(x_k)[a_{m+1,-1}B^{(-1)}(y_l) + a_{m+1,0}B^{(0)}(y_l)+ \\ &+a_{m+1,1}B^{(1)}(y_l) + \dots + a_{m+1,n+1}B^{(n+1)}(y_l)] = z_{k,l} \end{aligned}$$

It follows from the fundamental properties of cubic B-splines that they take zero values if $j \leq l - 2, j \geq l + 2, k \leq i - 2,$ and $k \geq i + 2,$ see Appendix 1. Due to this feature the above equation reduces itself to

$$\begin{aligned} &B^{(k-1)}(x_k)[a_{k-1,l-1}B^{(l-1)}(y_l) + a_{k-1,l}B^{(l)}(y_l)+ \\ &+a_{k-1,l+1}B^{(l+1)}(y_l)] + B^{(k)}(x_k)[a_{k,l-1}B^{(l-1)}(y_l)+ \\ &\quad +a_{k,l}B^{(l)}(y_l) + a_{k,l+1}B^{(l+1)}(y_l)]+ \\ &+B^{(k+1)}(x_k)[a_{k+1,l-1}B^{(l-1)}(y_l) + a_{k+1,l}B^{(l)}(y_l)+ \\ &\quad +a_{k+1,l+1}B^{(l+1)}(y_l)] = z_{k,l} \end{aligned} \quad (5)$$

The further reduction of equation (5) takes place when the following realtions

$$\begin{aligned} B^{(k-1)}(x_k) &= 1/6, & B^{(k)}(x_k) &= 4/6, & B^{(k+1)}(x_k) &= 1/6 \\ B^{(l-1)}(y_l) &= 1/6, & B^{(l)}(y_l) &= 4/6, & B^{(l+1)}(y_l) &= 1/6 \end{aligned} \quad (6)$$

are taken into account, see Table II presented in Appendix 1. Finally, we obtain

$$\begin{aligned} &(a_{k-1,j-1} + 4a_{k-1,l} + a_{k-1,l+1}) + 4(a_{k,l-1} + 4a_{k,l} + a_{k,l+1}) + \\ &+ (a_{k+1,l-1} + 4a_{k+1,l} + a_{k+1,l+1}) = 36z_{k,l} \end{aligned} \quad (7)$$

Equations similar to (7) are formulated for each node of the rectangular grid covering the interpolation region R which has been dashed in Fig.1. In such way a system of $(m + 1)(n + 1)$ independent equations is obtained. As mentioned earlier, the interpolating function $Q_2(x_k, y_l)$ contains $(m + 3)(n + 3)$ coefficients. To evaluate of them $(m + 3)(n + 3)$ independent equations are required. Thus, additional $2(m+n)+8$ equations should be formulated on the basis of proper boundary conditions. It follows from the literature that very good quality of interpolation can be achieved when the second-order partial derivatives of the interpolating function take zero values at border nodes, [5], [7], [8]. Boundary conditions formulated in this way describe the following equations

$$\begin{aligned} \frac{\partial^2 Q_2(x_k, y_l)}{\partial x^2} &= \frac{1}{6h_x^2} [a_{k-1,l-1} + 4a_{k-1,l} + a_{k-1,l+1}] + \\ &\quad - \frac{2}{6h_x^2} [a_{k,l-1} + 4a_{k,l} + a_{k,l+1}] + \\ &\quad + \frac{1}{6h_x^2} [a_{k+1,l-1} + 4a_{k+1,l} + a_{k+1,l+1}] = 0 \end{aligned} \quad (8)$$

for $k = 0, m$ and $0 \leq l \leq n$

$$\begin{aligned} \frac{\partial^2 Q_2(x_k, y_l)}{\partial y^2} &= \frac{1}{6h_y^2} [a_{k-1,l-1} + 4a_{k,l-1} + a_{k+1,l-1}] + \\ &\quad - \frac{2}{6h_y^2} [a_{k-1,l} + 4a_{k,l} + a_{k+1,l}] + \\ &\quad + \frac{1}{6h_y^2} [a_{k-1,l+1} + 4a_{k,l+1} + a_{k+1,l+1}] = 0 \end{aligned} \quad (9)$$

for $l = 0, n$ and $0 \leq k \leq m$

where $h_x = x_{k+1} - x_k$ and $h_y = y_{l+1} - y_l$. The number of equations described by fomulae (8) and (9) is equal to $2m + 2n + 4$. Four missing equations are formulated for corner nodes, i.e. $(x_0, y_0), (x_0, y_n), (x_m, y_0)$ and (x_m, y_n) , in the form

$$\begin{aligned} \frac{\partial^4 Q_2(x_k, y_l)}{\partial x^2 \partial y^2} &= \frac{\partial^4 Q_2(x_k, y_l)}{\partial y^2 \partial x^2} = \\ &= \frac{1}{h_x^2 h_y^2} [a_{k-1,l-1} - 2a_{k,l-1} + a_{k+1,l-1}] + \\ &\quad - \frac{2}{h_x^2 h_y^2} [a_{k-1,l} - 2a_{k,l} + a_{k+1,l}] + \\ &\quad + \frac{1}{h_x^2 h_y^2} [a_{k-1,l+1} - 2a_{k,l+1} + a_{k+1,l+1}] = 0 \end{aligned} \quad (10)$$

Now, the overall number of equations, described by formulae (7)-(10), is equal to $(m + 3)(n + 3)$ and is equal to the number of coefficients $a_{i,j}$ being sought. Naturally, the system of equations formulated on a basis of (7)-(10) is linear with respect to coefficients $a_{i,j}$ and cen be written in a standard matrix form

$$\mathbf{C} \cdot \mathbf{A} = \mathbf{Z} \quad (11)$$

where:

$$C = \begin{bmatrix} [M_1][M_2][M_1] & & & & & & & & \\ [M_1][M_3][M_1] & & & & & & & & \\ & [M_1][M_3][M_1] & & & & & & & \\ & & [M_1][M_3][M_1] & & & & & & \\ & & & [M_1][M_3][M_1] & & & & & \\ & & & & [M_1][M_3][M_1] & & & & \\ & & & & & [M_1][M_3][M_1] & & & \\ & & & & & & [M_1][M_3][M_1] & & \\ & & & & & & & [M_1][M_3][M_1] & \\ & & & & & & & & [M_1][M_3][M_1] \end{bmatrix} \quad (12)$$

is the square matrix of degree $(m + 3)(n + 3)$ and it is composed of $2(m + 3)$ matrices $[M_1]$, 2 matrices $[M_2]$ and $(m + 1)$ matrices $[M_3]$. All these component matrices (blocks) are of degree $(n + 3)$ and have the following square structures.

$$[M_1] = \begin{bmatrix} 1 & -2 & 1 & 0 & \dots & 0 & 0 & 0 & 0 \\ 1 & 4 & 1 & 0 & \dots & 0 & 0 & 0 & 0 \\ 0 & 1 & 4 & 1 & \dots & 0 & 0 & 0 & 0 \\ \dots & \dots & \dots & \dots & \dots & \dots & \dots & \dots & \dots \\ 0 & 0 & 0 & 0 & \dots & 1 & 4 & 1 & 0 \\ 0 & 0 & 0 & 0 & \dots & 0 & 1 & 4 & 1 \\ 0 & 0 & 0 & 0 & \dots & 0 & 1 & -2 & 1 \end{bmatrix}_{(n+3) \times (n+3)}$$

$$[M_2] = \begin{bmatrix} -2 & 4 & -2 & 0 & \dots & 0 & 0 & 0 & 0 \\ -2 & -8 & -2 & 0 & \dots & 0 & 0 & 0 & 0 \\ 0 & -2 & -8 & -2 & \dots & 0 & 0 & 0 & 0 \\ \dots & \dots & \dots & \dots & \dots & \dots & \dots & \dots & \dots \\ 0 & 0 & 0 & 0 & \dots & -2 & -8 & -2 & 0 \\ 0 & 0 & 0 & 0 & \dots & 0 & -2 & -8 & -2 \\ 0 & 0 & 0 & 0 & \dots & 0 & -2 & 4 & -2 \end{bmatrix}_{(n+3) \times (n+3)}$$

$$[M_3] = \begin{bmatrix} 4 & -8 & 4 & 0 & \dots & 0 & 0 & 0 & 0 \\ 4 & 16 & 4 & 0 & \dots & 0 & 0 & 0 & 0 \\ 0 & 4 & 16 & 4 & \dots & 0 & 0 & 0 & 0 \\ \dots & \dots & \dots & \dots & \dots & \dots & \dots & \dots & \dots \\ 0 & 0 & 0 & 0 & \dots & 4 & 16 & 4 & 0 \\ 0 & 0 & 0 & 0 & \dots & 0 & 4 & 16 & 4 \\ 0 & 0 & 0 & 0 & \dots & 0 & 4 & -8 & 4 \end{bmatrix}_{(n+3) \times (n+3)}$$

The vector \mathbf{A} of variables (coefficients $a_{i,j}$) as well as vector \mathbf{Z} of the free terms, see equation (11), have a column – block form, i.e.

$$\mathbf{A} = \begin{bmatrix} [A_{-1}] \\ [A_0] \\ [A_1] \\ [A_2] \\ \dots \\ [A_{m-2}] \\ [A_{m-1}] \\ [A_m] \\ [A_{m+1}] \end{bmatrix}_{1 \times (m \cdot n + 3m + 3n + 9)} \quad (14)$$

$$\mathbf{Z} = \begin{bmatrix} [Z_{-1}] \\ [Z_0] \\ [Z_1] \\ [Z_2] \\ \dots \\ [Z_{m-2}] \\ [Z_{m-1}] \\ [Z_m] \\ [Z_{m+1}] \end{bmatrix}_{1 \times (m \cdot n + 3m + 3n + 9)}$$

and are composed of the following blocks

$$[A_{-1}] = \begin{bmatrix} a_{-1,-1} \\ a_{-1,0} \\ a_{-1,1} \\ a_{-1,2} \\ \dots \\ a_{-1,n} \\ a_{-1,n+1} \end{bmatrix}, \quad [A_0] = \begin{bmatrix} a_{0,-1} \\ a_{0,0} \\ a_{0,1} \\ a_{0,2} \\ \dots \\ a_{0,n} \\ a_{0,n+1} \end{bmatrix},$$

$$[A_1] = \begin{bmatrix} a_{1,-1} \\ a_{1,0} \\ a_{1,1} \\ a_{1,2} \\ \dots \\ a_{1,n} \\ a_{1,n+1} \end{bmatrix}, \dots, [A_{m+1}] = \begin{bmatrix} a_{m+1,-1} \\ a_{m+1,0} \\ a_{m+1,1} \\ a_{m+1,2} \\ \dots \\ a_{m+1,n} \\ a_{m+1,n+1} \end{bmatrix} \quad (15)$$

$$[Z_{-1}] = [Z_{m+1}] = \begin{bmatrix} 0 \\ 0 \\ 0 \\ \dots \\ 0 \\ 0 \end{bmatrix}, \quad [Z_0] = \begin{bmatrix} 0 \\ 36z_{0,0} \\ 36z_{0,1} \\ 36z_{0,2} \\ \dots \\ 36z_{0,n} \\ 0 \end{bmatrix},$$

$$[Z_1] = \begin{bmatrix} 0 \\ 36z_{1,0} \\ 36z_{1,1} \\ 36z_{1,2} \\ \dots \\ 36z_{1,n} \\ 0 \end{bmatrix}, \dots, [Z_m] = \begin{bmatrix} 0 \\ 36z_{m,0} \\ 36z_{m,1} \\ 36z_{m,2} \\ \dots \\ 36z_{m,n} \\ 0 \end{bmatrix} \quad (16)$$

The next stage of presented algorithm is solving the system of equations which contains $(m + 1)(n + 1)$ independent equations defined by general formula (7) and $2m + 2n + 8$ equations related to boundary conditions described by (8)-(10).

In general, equation system (11) can be solved by means of standard Gauss elimination method [6], [9] However, in many cases this approach can be non-effective, because matrix (12) is sparse. In other words it contains $[(m + 3)(n + 3)]^2$

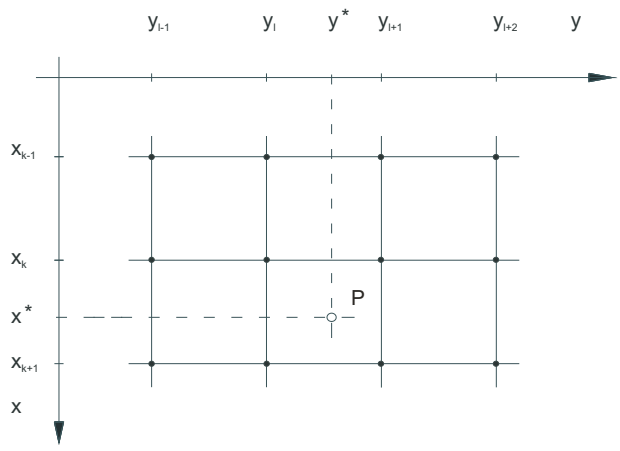

Fig. 2. A sector of the interpolation region placed around an internal node (x_k, y_l) .

elements, from which only $9(m+3)(n+3)$ ones take values different from zero. For sufficiently big values of m and n the relative number of non-zero elements is of several percent. For instance, if $m > 7$ and $n > 7$ then it is less than 9%. It is obvious that in such cases the system (11) should be solved by using one of special versions of Gauss elimination method [8], [10], [11].

Thus, let us assume that the values of coefficients $a_{i,j}$ are known. Let us assume also that a non-node point $P(x, y)$ lies in close vicinity of the node (x_k, y_l) , as illustrated in Fig. 2.

In such a situation the value of the interpolating function $Z(x, y) \equiv Q_2(x, y)$ at point $P(x, y)$ is calculated according to the following formula:

$$\begin{aligned}
 Z(x, y) = & B^{(k-1)}(x)[a_{k-1,l-1}B^{(l-1)}(y) + a_{k-1,l}B^{(l)}(y) + \\
 & + a_{k-1,l+1}B^{(l+1)}(y) + a_{k-1,l+2}B^{(l+2)}(y)] + \\
 & + B^{(k)}(x)[a_{k,l-1}B^{(l-1)}(y) + a_{k,l}B^{(l)}(y) + a_{k,l+1}B^{(l+1)}(y) + \\
 & + a_{k,l+2}B^{(l+2)}(y)] + B^{(k+1)}(x)[a_{k+1,l-1}B^{(l-1)}(y) + \\
 & + a_{k+1,l}B^{(l)}(y) + a_{k+1,l+1}B^{(l+1)}(y) + a_{k+1,l+2}B^{(l+2)}(y)] + \\
 & + B^{(k+2)}(x)[a_{k+2,l-1}B^{(l-1)}(y) + a_{k+2,l}B^{(l)}(y) + \\
 & + a_{k+2,l+1}B^{(l+1)}(y) + a_{k+2,l+2}B^{(l+2)}(y)] \quad (17)
 \end{aligned}$$

where k and l are the biggest integral indices for which $k \cdot h_x < x$ and $l \cdot h_y < y$. The values of B-splines occurring in the formula (17) can be easily calculated by using the formulae (18) given in Appendix 1.

III. THE EXAMPLE OF TWO-DIMENSIONAL INTERPOLATION

In this section the interpolating function $Z(x, y) \equiv Q_2(x, y)$ is evaluated on the basis of the two-variable function $z_{i,j} = z(x_i, y_j)$ given in Table 1. This function is determined by 42 discrete values of $z_{i,j} = z(x_i, y_j)$ specified at 42 uniformly spaced nodes (x_i, y_j) , of the interpolation region $R : \{(x, y), x_0 \leq x \leq x_m, y_0 \leq y \leq y_n\}$. These values of characteristic impedance (expressed in ohms) have been evaluated numerically (by means of the finite difference method) for a shielded coaxial slab transmission line whose transverse section is shown in Fig. 3, [3], [4], [9], [12], [13].

According to the theory presented in the previous section, see formulae (16), column vector \mathbf{Z} formulated for this interpolation problem contains 72 elements and is composed of $(m+3) = 8$ 9-element blocks. Some of them are given below.

$$[Z_{-1}] = 36 \begin{bmatrix} z_{-1,-1} \\ z_{-1,0} \\ z_{-1,1} \\ z_{-1,2} \\ z_{-1,3} \\ z_{-1,4} \\ z_{-1,5} \\ z_{-1,6} \\ z_{-1,7} \end{bmatrix} = \begin{bmatrix} z_1 \\ z_2 \\ z_3 \\ z_4 \\ z_5 \\ z_6 \\ z_7 \\ z_8 \\ z_9 \end{bmatrix} = \begin{bmatrix} 0 \\ 0 \\ 0 \\ 0 \\ 0 \\ 0 \\ 0 \\ 0 \\ 0 \end{bmatrix},$$

$$\begin{aligned}
 [Z_0] = 36 \begin{bmatrix} z_{0,-1} \\ z_{0,0} \\ z_{0,1} \\ z_{0,2} \\ z_{0,3} \\ z_{0,4} \\ z_{0,5} \\ z_{0,6} \\ z_{0,7} \end{bmatrix} &= \begin{bmatrix} z_{10} \\ z_{11} \\ z_{12} \\ z_{13} \\ z_{14} \\ z_{15} \\ z_{16} \\ z_{17} \\ z_{18} \end{bmatrix} = \begin{bmatrix} 0 \\ 2771.28 \\ 2813.04 \\ 2832.48 \\ 2840.76 \\ 2845.08 \\ 2846.88 \\ 2847.60 \\ 0 \end{bmatrix}, \\
 [Z_1] = 36 \begin{bmatrix} z_{1,-1} \\ z_{1,0} \\ z_{1,1} \\ z_{1,2} \\ z_{1,3} \\ z_{1,4} \\ z_{1,5} \\ z_{1,6} \\ z_{1,7} \end{bmatrix} &= \begin{bmatrix} z_{19} \\ z_{20} \\ z_{21} \\ z_{22} \\ z_{23} \\ z_{24} \\ z_{25} \\ z_{26} \\ z_{27} \end{bmatrix} = \begin{bmatrix} 0 \\ 2647.80 \\ 2689.56 \\ 2708.64 \\ 2716.56 \\ 2721.24 \\ 2723.04 \\ 2724.12 \\ 0 \end{bmatrix}, \dots, \\
 [Z_6] = 36 \begin{bmatrix} z_{6,-1} \\ z_{6,0} \\ z_{6,1} \\ z_{6,2} \\ z_{6,3} \\ z_{6,4} \\ z_{6,5} \\ z_{6,6} \\ z_{6,7} \end{bmatrix} &= \begin{bmatrix} z_{64} \\ z_{65} \\ z_{66} \\ z_{67} \\ z_{68} \\ z_{69} \\ z_{70} \\ z_{71} \\ z_{72} \end{bmatrix} = \begin{bmatrix} 0 \\ 0 \\ 0 \\ 0 \\ 0 \\ 0 \\ 0 \\ 0 \\ 0 \end{bmatrix}
 \end{aligned}$$

A solution of the matrix equation (11) is column vector \mathbf{A} containing 72 elements, i.e. coefficients $a_{i,j}$ of the interpolating function (3) being sought. Below, this vector is presented as a block one, see formulae (14) and (15), composed of $(m+3) = 8$ blocks $[A_{-1}] - [A_6]$.

$$[A_{-1}] = \begin{bmatrix} a_{-1,-1} \\ a_{-1,0} \\ a_{-1,1} \\ a_{-1,2} \\ a_{-1,3} \\ a_{-1,4} \\ a_{-1,5} \\ a_{-1,6} \\ a_{-1,7} \end{bmatrix} = \begin{bmatrix} a_1 \\ a_2 \\ a_3 \\ a_4 \\ a_5 \\ a_6 \\ a_7 \\ a_8 \\ a_9 \end{bmatrix} = \begin{bmatrix} 84.04900945 \\ 84.78287081 \\ 85.51673218 \\ 86.08589425 \\ 86.15892529 \\ 86.38998356 \\ 86.39492038 \\ 86.44928230 \\ 86.50364422 \end{bmatrix},$$

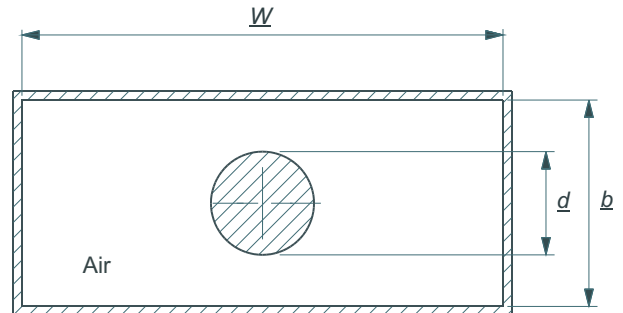

Fig. 3. The transverse section of the shielded coaxial slab transmission line.

TABLE I

$x = d/b$	$y = W/b$						
	$y_0 = 1.50$	$y_1 = 1.75$	$y_2 = 2.00$	$y_3 = 2.25$	$y_4 = 2.50$	$y_5 = 2.75$	$y_6 = 3.00$
$x_0 = 0.32$	80.83	81.79	82.32	82.53	82.67	82.72	82.75
$x_1 = 0.34$	76.98	78.14	78.68	78.91	79.03	79.08	79.10
$x_2 = 0.36$	73.55	74.71	75.24	75.46	75.59	75.64	75.67
$x_3 = 0.38$	70.29	71.45	71.98	72.20	72.34	72.38	72.41
$x_4 = 0.40$	67.20	68.36	68.89	69.14	69.25	69.29	69.32
$x_5 = 0.42$	64.26	65.42	65.95	66.18	66.31	66.36	66.38

$$[A_0] = \begin{bmatrix} a_{0,-1} \\ a_{0,0} \\ a_{0,1} \\ a_{0,2} \\ a_{0,3} \\ a_{0,4} \\ a_{0,5} \\ a_{0,6} \\ a_{0,7} \end{bmatrix} = \begin{bmatrix} a_{10} \\ a_{11} \\ a_{12} \\ a_{13} \\ a_{14} \\ a_{15} \\ a_{16} \\ a_{17} \\ a_{18} \end{bmatrix} = \begin{bmatrix} 79.77684615 \\ 80.83000001 \\ 81.88315385 \\ 82.37738462 \\ 82.52730769 \\ 82.69338462 \\ 82.71915385 \\ 82.75000002 \\ 82.78084615 \end{bmatrix}, \quad [A_4] = \begin{bmatrix} a_{4,-1} \\ a_{4,0} \\ a_{4,1} \\ a_{4,2} \\ a_{4,3} \\ a_{4,4} \\ a_{4,5} \\ a_{4,6} \\ a_{4,7} \end{bmatrix} = \begin{bmatrix} a_{46} \\ a_{47} \\ a_{48} \\ a_{49} \\ a_{50} \\ a_{51} \\ a_{52} \\ a_{53} \\ a_{54} \end{bmatrix} = \begin{bmatrix} 65.85906748 \\ 67.17076555 \\ 68.48246362 \\ 68.87823163 \\ 69.16173905 \\ 69.22323322 \\ 69.25700271 \\ 69.28980861 \\ 69.32261453 \end{bmatrix},$$

$$[A_1] = \begin{bmatrix} a_{1,-1} \\ a_{1,0} \\ a_{1,1} \\ a_{1,2} \\ a_{1,3} \\ a_{1,4} \\ a_{1,5} \\ a_{1,6} \\ a_{1,7} \end{bmatrix} = \begin{bmatrix} a_{19} \\ a_{20} \\ a_{21} \\ a_{22} \\ a_{23} \\ a_{24} \\ a_{25} \\ a_{26} \\ a_{27} \end{bmatrix} = \begin{bmatrix} 75.50468286 \\ 76.87712919 \\ 78.24957551 \\ 78.66887498 \\ 78.89569010 \\ 78.99678567 \\ 79.04338731 \\ 79.05071770 \\ 79.05804809 \end{bmatrix}, \quad [A_5] = \begin{bmatrix} a_{5,-1} \\ a_{5,0} \\ a_{5,1} \\ a_{5,2} \\ a_{5,3} \\ a_{5,4} \\ a_{5,5} \\ a_{5,6} \\ a_{5,7} \end{bmatrix} = \begin{bmatrix} a_{55} \\ a_{56} \\ a_{57} \\ a_{58} \\ a_{59} \\ a_{60} \\ a_{61} \\ a_{62} \\ a_{63} \end{bmatrix} = \begin{bmatrix} 62.95117949 \\ 64.26000001 \\ 65.56882051 \\ 65.98471795 \\ 66.19230769 \\ 66.32605128 \\ 66.36348718 \\ 66.38000001 \\ 66.39651282 \end{bmatrix},$$

$$[A_2] = 36 \begin{bmatrix} a_{2,-1} \\ a_{2,0} \\ a_{2,1} \\ a_{2,2} \\ a_{2,3} \\ a_{2,4} \\ a_{2,5} \\ a_{2,6} \\ a_{2,7} \end{bmatrix} = \begin{bmatrix} a_{28} \\ a_{29} \\ a_{30} \\ a_{31} \\ a_{32} \\ a_{33} \\ a_{34} \\ a_{35} \\ a_{36} \end{bmatrix} = \begin{bmatrix} 72.25042240 \\ 73.54148325 \\ 74.83254411 \\ 75.25111545 \\ 75.43993191 \\ 75.57547270 \\ 75.61329690 \\ 75.64712919 \\ 75.68096148 \end{bmatrix}, \quad [A_6] = \begin{bmatrix} a_{6,-1} \\ a_{6,0} \\ a_{6,1} \\ a_{6,2} \\ a_{6,3} \\ a_{6,4} \\ a_{6,5} \\ a_{6,6} \\ a_{6,7} \end{bmatrix} = \begin{bmatrix} a_{64} \\ a_{65} \\ a_{66} \\ a_{67} \\ a_{68} \\ a_{69} \\ a_{70} \\ a_{71} \\ a_{72} \end{bmatrix} = \begin{bmatrix} 60.04329150 \\ 61.34923445 \\ 62.65517740 \\ 63.09120427 \\ 63.22287633 \\ 63.42886934 \\ 63.46997166 \\ 63.47019139 \\ 63.47041112 \end{bmatrix},$$

It has been confirmed by numerous computer simulations that interpolating function $Z(x, y) \equiv Q_2(x, y)$ evaluated above takes values $z_{k,l}$ ascribed to the particular nodes (x_k, y_l) of the interpolation region $R : \{(x, y), x_0 \leq x \leq x_m, y_0 \leq y \leq y_n\}$. Undoubtedly, this fact confirms correctness of presented interpolation method. Naturally, at any non-node point, for example $(x^* = 0.37, y^* = 2.35)$, the function $Z(x, y)$ can be written as

$$[A_3] = 36 \begin{bmatrix} a_{3,-1} \\ a_{3,0} \\ a_{3,1} \\ a_{3,2} \\ a_{3,3} \\ a_{3,4} \\ a_{3,5} \\ a_{3,6} \\ a_{3,7} \end{bmatrix} = \begin{bmatrix} a_{37} \\ a_{38} \\ a_{39} \\ a_{40} \\ a_{41} \\ a_{42} \\ a_{43} \\ a_{44} \\ a_{45} \end{bmatrix} = \begin{bmatrix} 68.94624291 \\ 70.25693780 \\ 71.56763268 \\ 71.99712477 \\ 72.15535149 \\ 72.34778506 \\ 72.34680972 \\ 72.38076555 \\ 72.41472128 \end{bmatrix},$$

$$Z(x^*, y^*) = B^{(k-1)}(x^*)[a_{k-1,l-1}B^{(l-1)}(y^*) + a_{k-1,l}B^{(l)}(y^*) + a_{k-1,l+1}B^{(l+1)}(y^*) + a_{k-1,l+2}B^{(l+2)}(y^*)] + B^{(k)}(x^*)[a_{k,l-1}B^{(l-1)}(y^*) + a_{k,l}B^{(l)}(y^*) + a_{k,l+1}B^{(l+1)}(y^*) + a_{k,l+2}B^{(l+2)}(y^*)] + B^{(k+1)}(x^*)[a_{k+1,l-1}B^{(l-1)}(y^*) + a_{k+1,l}B^{(l)}(y^*) + a_{k+1,l+1}B^{(l+1)}(y^*) + a_{k+1,l+2}B^{(l+2)}(y^*)] + B^{(k+2)}(x^*)[a_{k+2,l-1}B^{(l-1)}(y^*) + a_{k+2,l}B^{(l)}(y^*) +$$

$$+a_{k+2,l+1}B^{(l+1)}(y^*) + a_{k+2,l+2}B^{(l+2)}(y^*)]$$

where: $k = 2, l = 3, h_x = 0.02, h_y = 0.25, \Delta x^* = x^* - x_k = 0.37 - 0.36 = 0.01, \Delta y^* = y^* - y_l = 2.35 - 2.25 = 0.1,$

$$B^{(k-1)}(x^*) = \frac{1}{6h_x^3} [2h_x - (x_{k-1} + h_x + \Delta x^*) + x_{k-1}]^3 =$$

$$= \frac{1}{6h_x^3} (h_x - \Delta x^*)^3 = 0.020833333$$

$$B^{(k)}(x^*) = \frac{1}{6h_x^3} [3(\Delta x^*)^3 - 6(\Delta x^*)^2 h_x + 4h_x^3] = 0.479166653$$

$$B^{(k+1)}(x^*) = \frac{1}{6h_x^3} [-3(\Delta x^* - h_x)^3 - 6(\Delta x^* - h_x)^2 h_x + 4h_x^3] =$$

$$= 0.479166653$$

$$B^{(k+2)}(x^*) = \frac{1}{6h_x^3} (x_{k+2} - 2h_x + \Delta x^* - x_{k+2} + 2h_x)^3 =$$

$$= \frac{1}{6h_x^3} (\Delta x^*)^3 = 0.020833333$$

$$B^{(l-1)}(y^*) = \frac{1}{6h_y^3} [2h_y - (y_{l-1} + h_y + \Delta y^*) + y_{l-1}]^3 =$$

$$= \frac{1}{6h_y^3} (h_y - \Delta y^*)^3 = 0.036000004$$

$$B^{(l)}(y^*) = \frac{1}{6h_y^3} [3(\Delta y^*)^3 - 6(\Delta y^*)^2 h_y + 4h_y^3] = 0.538666684$$

$$B^{(l+1)}(y^*) = \frac{1}{6h_y^3} [-3(\Delta y^* - h_y)^3 - 6(\Delta y^* - h_y)^2 h_y + 4h_y^3] =$$

$$= 0.414666675$$

$$B^{(l+2)}(y^*) = \frac{1}{6h_y^3} (y_{l+2} - 2h_y + \Delta y^* - y_{l+2} + 2h_y)^3 =$$

$$= \frac{1}{6h_y^3} (\Delta y^*)^3 = 0.010666666$$

All values of B-splines listed above have been calculated according to formula (18) given in Appendix 1. After introducing these values and corresponding values of coefficients $a_{i,j}$ (appropriate elements of vector \mathbf{A}) into the interpolating function $Z(x^*, y^*)$ we obtain $Z(x = 0.37, y = 2.35) = 73.869390$. The numerical results presented so far have been calculated by means of computer program SPLINE elaborated on the basis of theory presented in section 2 and Appendix 1. This program has been also used for computing the three plane sections of $Z(x, y)$, namely $Z(x = 0.40, 1.5 \leq y \leq 3.0)$, $Z(x = 0.42, 1.5 \leq y \leq 3.0)$ and $Z(0.32 \leq x \leq 0.42, y = 2.5)$ depicted in Figs.4 and 5, respectively.

It should be pointed out here that function $Z(x, y)$ is smooth enough, even near to the borders of interpolation region R . Indirectly, this fact confirms the proper choice of boundary conditions described by equations (8)-(10).

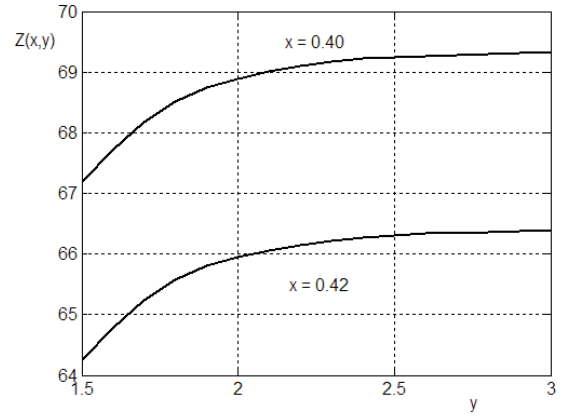

Fig. 4. Plane sections $Z(x = 0.40, 1.5 \leq y \leq 3)$ and $Z(x = 0.42, 1.5 \leq y \leq 3)$ of the interpolating function $Z(x, y)$.

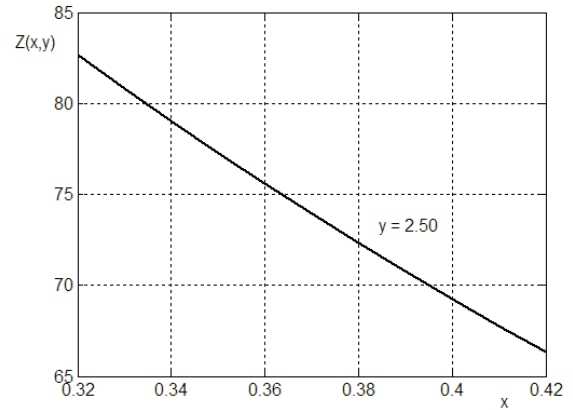

Fig. 5. The plane section $Z(0.32 \leq x \leq 0.42, y = 2.5)$ of the interpolating function $Z(x, y)$.

IV. CONCLUSIONS

The main didactic purpose of the paper is to show how the linear combination of bicubic B-splines can be effectively used in the two-dimensional interpolation. It is assumed that discrete values of a function to be interpolated are ascribed to the uniformly spaced nodes of a rectangular grid covering the interpolation region. All formulae of importance have been derived step by step and are presented in the form especially convenient for computer implementations. To ensure clarity of considerations, a short description of the one-dimensional cubic B-spline is also given in Appendix 1. The theory presented in section 2 and both appendices have been used in section 3 to two-dimensional interpolate of 42 values of characteristic impedance of the shielded coaxial slab transmission line. The obtained results confirm completely correctness of the proposed approach. Due to proper choice of boundary conditions, see equations (8)-(10), very good quality of interpolation has been achieved. In other words, ripples of the evaluated interpolating function $Z(x, y)$ are neglectable small near to borders of the interpolation region. This significant conclusion is well illustrated by the three plane sections of $Z(x, y)$ shown in Figs. 4 and 5.

APPENDIX 1

NORMALISED CUBIC B-SPLINES

The $B^{(i)}(x)$ spline being used in this paper is a polynomial of degree $m = 3$ taking positive non-zero values on an interval $[x_i - 2h, x_i + 2h]$, as illustrated in Fig.6. According to [1], [2] this polynomial can be written as

$$B^{(i)}(x) = \frac{1}{6h^3} \begin{cases} 0 & \text{for } x \leq (x_i - 2h) \\ (x - x_i + 2h)^3 & \text{for } (x_i - 2h) \leq x \leq (x_i - h) \\ -3(x - x_i)^3 - 6(x - x_i)^2h + 4h^3 & \text{for } (x_i - h) \leq x \leq x_i \\ 3(x - x_i)^3 - 6(x - x_i)^2h + 4h^3 & \text{for } x_i \leq x \leq (x_i + h) \\ (2h - x + x_i)^3 & \text{for } (x_i + h) \leq x \leq (x_i + 2h) \\ 0 & \text{for } x \geq (x_i + 2h) \end{cases} \quad (18)$$

where x_i denotes its central node and h is th distance between any adjacent nodes. As it is visible in Fig.6, function (18) takes the value of $4/6$ at the central node x_i and is equal to $1/6$ at adjacent nodes, namely at x_{i-1} and x_{i+1} . At nodes x_{i-2} , x_{i+2} (often called endpoints) and outside of the interval $[x_i - 2h, x_i + 2h]$ the function under discussion is equal to 0. The first-order and second-order derivatives of $B^{(i)}(x)$ can be easily calculated by using the following formulae.

$$\frac{dB^{(i)}(x)}{dx} = \frac{1}{6h^3} \begin{cases} 0 & \text{for } x \leq (x_i - 2h) \\ 3(x - x_i + 2h)^2 & \text{for } (x_i - 2h) \leq x \leq (x_i - h) \\ -9(x - x_i)^2 - 12(x - x_i)h & \text{for } (x_i - h) \leq x \leq x_i \\ 9(x - x_i)^2 - 12(x - x_i)h & \text{for } x_i \leq x \leq (x_i + h) \\ -3(2h - x + x_i)^2 & \text{for } (x_i + h) \leq x \leq (x_i + 2h) \\ 0 & \text{for } x \geq (x_i + 2h) \end{cases} \quad (19)$$

$$\frac{d^2B^{(i)}(x)}{dx^2} = \frac{1}{6h^3} \begin{cases} 0 & \text{for } x \leq (x_i - 2h) \\ 6(x - x_i + 2h) & \text{for } (x_i - 2h) \leq x \leq (x_i - h) \\ -18(x - x_i) - 12h & \text{for } (x_i - h) \leq x \leq x_i \\ 18(x - x_i) - 12h & \text{for } x_i \leq x \leq (x_i + h) \\ 6(2h - x + x_i) & \text{for } (x_i + h) \leq x \leq (x_i + 2h) \\ 0 & \text{for } x \geq (x_i + 2h) \end{cases} \quad (20)$$

It follows from the above formulae that first-order and second-order derivatives of $B^{(i)}(x)$ are continuous over the whole interval $[x_i - 2h, x_i + 2h]$, i.e. for $(x_i - 2h) < x < (x_i + 2h)$. Consequently they are continuous at internal nodes $x_{i-1} = x_i - h$, x_i and $x_{i+1} = x_i + h$. Values

TABLE II

$x \rightarrow$	$x_i - 2h$	$x_i - h$	x_i	$x_i + h$	$x_i + 2h$
$B^{(i)}(x)$	0	$\frac{1}{6}$	$\frac{4}{6}$	$\frac{1}{6}$	0
$\frac{dB^{(i)}(x)}{dx}$	0	$\frac{1}{2h}$	0	$-\frac{1}{2h}$	0
$\frac{d^2B^{(i)}(x)}{dx^2}$	0	$\frac{1}{h^2}$	$-\frac{2}{h^2}$	$\frac{1}{h^2}$	0

of $B^{(i)}(x)$, $\frac{dB^{(i)}(x)}{dx}$ and $\frac{d^2B^{(i)}(x)}{dx^2}$ evaluated on a basis of formulae (18)-(20) at particular nodes mentioned above are given in Table II.

The functions $B^{(i)}(x)$ defined for $i = k, k + 1, \dots$ are linearly independent. Hence, a linear combination of them is also a spline function. Due to this valuable feature, the linear combinations of cubic B-splines are particularly suitable for the interpolation and approximation purposes.

REFERENCES

- [1] H. E. Brenner, "Numerical Solution of TEM – Line Problems Involving Inhomogeneous Media," *IEEE Transactions on Microwave Theory and Techniques*, vol. 15, pp. 485–487, August 1967.
- [2] H. E. Green, "The Numerical Solution of Some Important Transmission – Line Problems," *IEEE Transactions on Microwave Theory and Techniques*, vol. 13, pp. 676–692, September 1965.
- [3] S. Rosloniec, *Algorithms for Computer-aided Design of Linear Microwave Circuits*. Boston (MA): Artech House Inc., 1990.
- [4] B. C. Wadell, *Transmission Line Design Handbook*. Boston (MA): Artech House Inc., 1991.
- [5] C. Boor, *A practical Guide to Splines – Second Edition*. New York: Springer-Verlag, 2001.
- [6] J. H. Mathews, *Numerical Methods for Mathematics, Science and Engineering*. Englewood Cliffs, N.J.: Prentice-Hall International Inc., 1992.
- [7] E. V. Shikin and A. I. Plis, *Handbook on Splines for the User*. New York: CRC Press, 1995.
- [8] P. Kiciak, *Private information of March 17*. Warsaw University, Department of Applied Mathematics and Mechanics, 2011.
- [9] S. Rosloniec, *Fundamental Numerical Methods for Electrical Engineering*. Heidelberg/Berlin: Springer Verlag, 2008.
- [10] T. A. Davis, *Direct Methods for Sparse Linear Systems*. Philadelphia (PA): SIAM Publishing House, 2006.
- [11] I. S. Duff, A. M. Erisman, and J. K. Reid, *Direct Methods for Sparse Matrices*. Oxford: Oxford University Press, 1989.
- [12] M. A. R. Gunston, *Microwave Transmission Line Impedance Data*. New York: Van Nostrand Reinhold Comp., 1972.
- [13] M. V. Schneider, "Computation of Impedance and Attenuation of TEM – Lines by Finite Difference Methods," *IEEE Transactions on Microwave Theory and Techniques*, vol. 13, pp. 793–800, November 1965.
- [14] M. N. O. Sadiku, *Numerical Techniques in Electromagnetics – Second Edition*. Boca Raton (Florida), London: CRC Press, 2001.

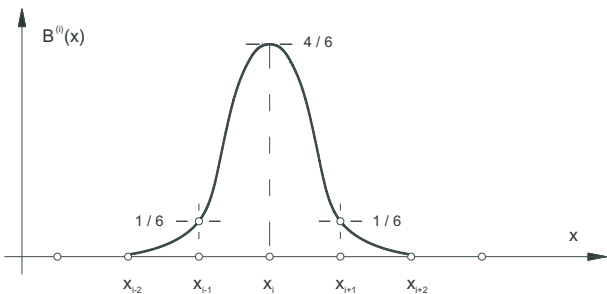

Fig. 6. The cubic B-spline defined in relation to its central node x_i .