

Current knowledge on supercapacitors, hybrid supercapacitors, and comparison with Lithium-Ion Cells – a review

Mariusz Staniak, and Mirosław Lewandowski

Abstract—The growing demand for efficient and durable energy storage technologies has accelerated the development and deployment of advanced electrochemical systems. This review presents a comparative analysis of three key energy storage technologies: electric double-layer capacitors (EDLC), lithium-ion hybrid capacitors (LIC), and conventional lithium-ion batteries. The study explores their internal structures, charge storage mechanisms (non-faradaic vs. faradaic), electrochemical characteristics, and performance parameters including energy density, power density, cycle life, and thermal stability.

LIC, which combine a capacitive electrode with a battery-type electrode, are shown to bridge the performance gap between EDLC and lithium-ion batteries by offering significantly higher power density and cycle life than batteries, and greater energy density and lower self-discharge than EDLC. Commercial examples such as SECH and VinaTech LIC are discussed in terms of operational parameters and practical deployment.

Quantitative comparisons indicate that LIC can reach energy densities up to 77 Wh/kg and withstand over 50,000 charge-discharge cycles, positioning them as promising candidates for high-frequency cycling, fast-charging, and hybrid grid-storage systems. The paper concludes that further advancements in electrode materials and solid-state electrolytes are essential to unlock the full potential of LIC in both mobile and stationary energy storage applications.

Keywords—energy storage; hybrid supercapacitor; EDLC; lithium-ion cell

Definition of terms-

- **Lithium-ion cell** – an electrochemical energy storage device that utilises lithium ions as charge carriers.
- **Supercapacitor / EDLC (electrochemical double layer capacitor)** – an energy storage device that stores charge at the electrode-electrolyte interface, using the so-called electric double layer.
- **Hybrid supercapacitor / lithium-ion hybrid supercapacitor / LIC / LIHS (lithium-ion hybrid supercapacitor)** – an energy storage device that combines features of both supercapacitors and lithium-ion cells.
- **Energy storage system** – a device designed for storing electrical energy, composed of energy-storing components such as lithium-ion cells, supercapacitors, hybrid supercapacitors, or a combination of these technologies.

I. INTRODUCTION

THE issue of electrical energy storage is currently of great significance to both the scientific and industrial communities. The revolution in electromobility, along with

fundamental changes in the European energy systems, has driven intensified research efforts. The European Union's new regulations on CO₂ emissions and its goal of achieving climate neutrality by 2050 [1] have led to closer collaboration between academia and industry in the search for innovative energy storage methods.

Lithium-ion cells currently dominate the electrochemical energy storage market [2]. Scientists and manufacturers of energy storage systems and electric vehicles are heavily invested in research and development in this field. The performance of lithium-ion cells depends on material, structural, and environmental factors. Numerous experiments are being conducted concerning electrolyte type (e.g., liquid vs. solid-state), packaging form, and electrode compositions. However, lithium-ion technology still faces limitations regarding power density, energy density, and operational parameters. A key consideration is also the longevity of the cell and the impact of the number of cycles and time on ageing processes.

Supercapacitors, which have been present on the market for many years, are commonly used in traction energy storage systems or as supplementary components for lithium-ion-based storage. However, they have not gained widespread use in electrical grid storage or electric vehicles.

Hybrid supercapacitors, which combine the advantages of both supercapacitors and lithium-ion cells, present a promising technology that could enhance the performance of currently available solutions.

In the era of increasing demand for electrical energy storage, it is crucial to understand the differences between the available battery and capacitor technologies. Electric Double-Layer Capacitors (EDLC), lithium-ion hybrid capacitors (also known as LIC – lithium-ion capacitors), and conventional lithium-ion batteries differ in their operating principles, internal structures, and performance parameters. This article provides a comparison of these three types of energy storage systems – their construction, charge storage mechanisms, operating characteristics, and development prospects. The potential applications in the electrical grid and in electric vehicles will also be discussed, along with information on the commercialization level of these solutions.

Authors are with Warsaw University of Technology, Poland (corresponding author e-mail: mariusz.staniak2.dokt@pw.edu.pl)



II. SUPERCAPACITOR (EDLC)

Research on supercapacitors began in Japan as early as 1972 [3]. Today, their manufacturing technology is mature, and they are produced on a large scale, finding applications in industry as well as consumer electronics. Like conventional capacitors, supercapacitors belong to the category of electrochemical energy sources, alongside fuel cells, galvanic cells, and batteries. However, they differ significantly from these energy sources in their characteristics.

A supercapacitor stores electrical energy through charge accumulation at the electrode-electrolyte interface. The boundary between the two phases forms a so-called electric double layer, created by charge separation between the metal surface and the counterions in the electrolyte solution [4]. For this reason, supercapacitors are also referred to as Electrochemical Double Layer Capacitors (EDLCs). In an EDLC, energy is stored physically through the adsorption of ions on the electrode surface and the charge separation in the electric double layer. This mechanism is non-faradaic – no chemical transformations (redox reactions) occur, and charge transfer across the phase boundary does not take place. In an ideal supercapacitor, the only phenomenon is the charge separation at the electrode-electrolyte interface; there is no oxidation or reduction of the electrode material, and the entire charge is stored electrostatically.

The schematic diagram of an EDLC with two porous electrodes separated by a separator, with ion layers of opposite charges forming at the electrode-electrolyte interface is shown in Figure 1.

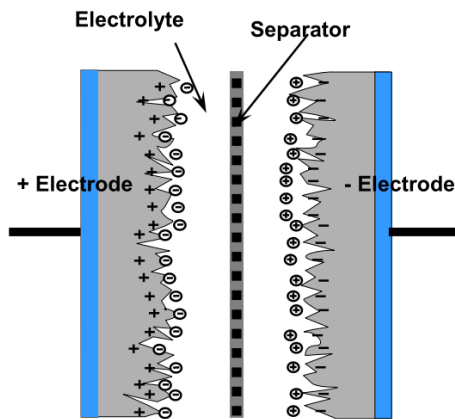

Fig. 1. Schematic representation of charge distribution in a supercapacitor [5]

The most common electrode materials for supercapacitors are conductive carbons and metal oxides [6]. The electrolyte typically consists of an aqueous solution of ionic substances, often strong acid or base salts that dissociate into stable ions. The dielectric separator between the electrodes is usually made of fibreglass or polymer gels.

A supercapacitor can be modelled using an equivalent circuit, as shown in Figure 2, which consists of:

- C – Capacitance, proportional to the dielectric permittivity (ϵ)
- RC – Equivalent series resistance
- RU – Equivalent leakage resistance
- L – Equivalent series inductance

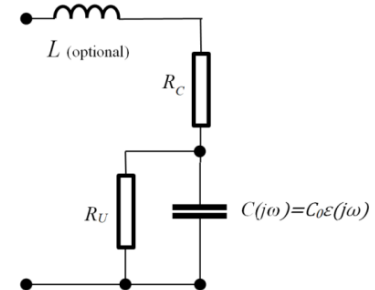

Fig. 2. Equivalent circuit of a supercapacitor

Depending on the level of detail in the equivalent circuit model, the values of these elements may be represented as fixed values or as functions of frequency, voltage, and temperature.

III. HYBRID SUPERCAPACITOR

Hybrid supercapacitors represent the latest advancement in the field of electrical energy storage. They have been developed in response to the rapidly growing demand for efficient and durable energy storage systems. These devices exhibit characteristics of both supercapacitors and lithium-ion cells, classifying them as potential candidates to bridge the gap in energy storage technology between conventional supercapacitors and lithium-ion batteries. Lithium-ion hybrid supercapacitors (LIHS) offer high energy density and the ability to facilitate bidirectional high-current transfer. At the same time, they are significantly less susceptible to self-discharge and provide greater power density [7].

Lithium-ion hybrid supercapacitors are constructed using a capacitor-type electrode and a lithium-ion battery-type electrode, which contains a lithium-ion electrolyte. Conventional double-layer supercapacitors store electrical energy by utilising the ion adsorption mechanism on the surface of the electrodes. In contrast, the novel type of hybrid supercapacitor stores electrical energy based on the movement of lithium ions from the negative electrode to the positive electrode during discharge, and in the opposite direction during charging. In this type of supercapacitor, a layered lithium oxide structure is used as the cathode material, while graphite or graphene serves as the anode material [8], [9]. Figure 3 schematically illustrates the concept of a hybrid supercapacitor as a combination of a lithium-ion cell and a conventional supercapacitor.

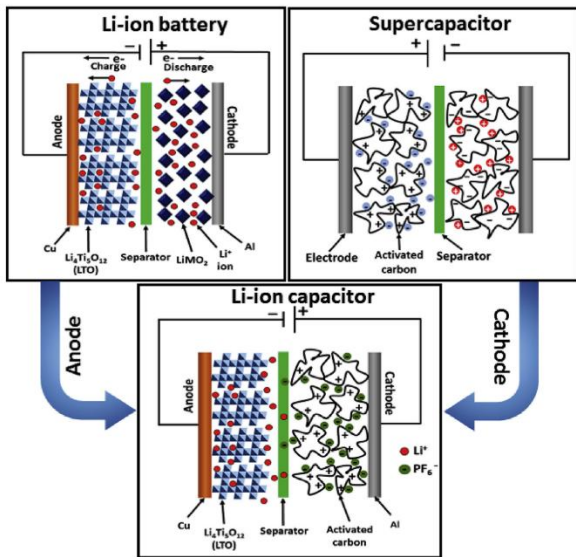

Fig. 2. Conceptual presentation of fabrication with Li-ion capacitors.

Fig. 3. Conceptual presentation of the structure and principle of operation of LICS [9]

The enrichment of lithium within the supercapacitor structure significantly increases power density compared to electric double-layer capacitors (EDLCs). The schematic design of lithium-prismatic capacitors, illustrated in Figure 4 using a product example from JM Energy, demonstrates an alternating arrangement of anodic and cathodic laminates, separated by insulating panels [10].

A lithium foil, which adheres to the anode, is directly connected to copper tabs. The introduction of an electrolyte facilitates the diffusion of doped lithium and the migration of positive charges toward the anode. The mass of the described prismatic cell is 350 g, with an operating voltage range of 2.2 – 3.8 V.

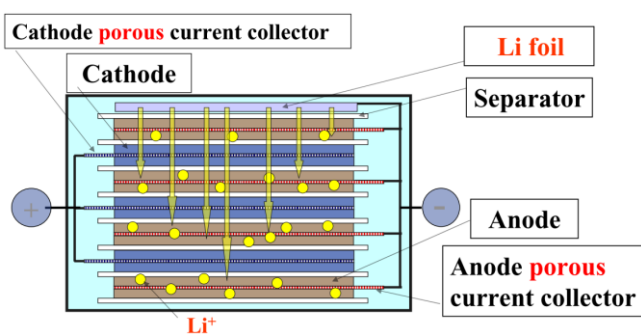

Fig. 4. Schematic structure of LICS based on the JM Energy product [10]

Lithium-ion supercapacitors exhibit a higher power density compared to lithium-ion batteries while simultaneously enhancing safety by eliminating the risk of a hazardous exothermic reaction, known as thermal runaway. They also

offer higher operating voltage and energy density than conventional supercapacitors. Another key advantage is their high resistance to ageing processes [11]. Figure 5 presents a comparison of lithium-ion capacitors (LICs) with other types of energy storage systems.

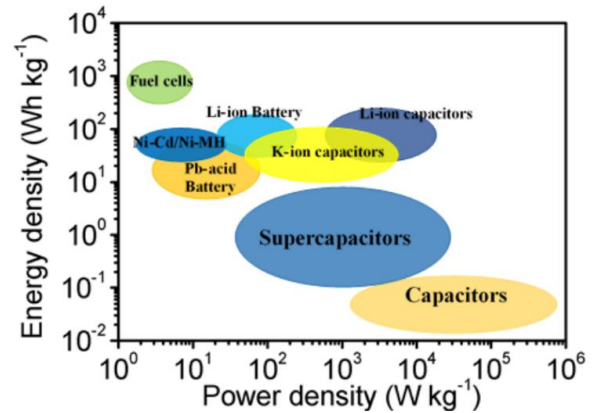

Fig. 5. Power density and energy density of individual types of energy storage [11]

The presented figure clearly illustrates the advantages of using lithium-ion supercapacitors (Li-ion capacitors). These devices exhibit a high power density comparable to that of traditional electric double-layer capacitors (EDLCs). At the same time, their energy density is several times greater, approaching that of lithium-ion batteries. This characteristic enables the storage of a significant amount of energy while allowing for the delivery of high power output.

Despite the availability of the first lithium-ion supercapacitors on the retail market, their production remains limited in scale, and only a few manufacturers offer a wide selection of such products. However, considering the undeniable advantages of this technology, its market presence is expected to grow significantly in the coming years. The rapid development of electromobility, the demand for local energy storage from renewable sources, and the increasing need for portable electrical power sources are likely to drive a continuous rise in demand for these energy storage devices.

Just as in the lithium-ion battery market, the field of hybrid supercapacitors is also exploring the potential for improving performance and durability by replacing conventional electrolytes with solid-state electrolytes. Ameziane et al. [12] presented a method for fast, reversible, and efficient control of the magnetic state of skyrmions — stable structures in nanostructured electrode materials of hybrid supercapacitors — through the accumulation and depletion of lithium ions at the magnetic interface under the influence of voltage. Although this technology remains in the research phase (similar to lithium-ion batteries with solid-state electrolytes), the results obtained so far appear promising.

Ongoing research is also focused on exploring various types of electrode materials to identify the most optimal solutions for lithium-ion capacitors (LICs). Standard anode materials include titanium oxide (TiO₂), iron oxide (Fe₂O₃), niobium nitride (NbN), and graphite-based carbon. Additionally, efforts are being made to develop hybrid anodes, which combine standard anode materials with conductive additives, such as carbon nanotubes or graphene [9].

Another promising approach involves nanostructuring the anode, which entails manipulating its structure at the nanoscale to enhance its efficiency. As a result, the anode achieves a larger active surface area, shorter ion diffusion paths, and improved structural stability [13].

IV. ADVANTAGES AND DISADVANTAGES OF SUPERCAPACITORS AND HYBRID SUPERCAPACITORS

An undeniable advantage of supercapacitors is their very high power density. Practical experience indicates that these components exhibit high resistance to degradation over time and after numerous charge-discharge cycles. When operating cycles are relatively short, high efficiency can be achieved. However, a significant drawback is their high susceptibility to self-discharge, which essentially disqualifies them as components for energy storage systems intended for integration with the power grid. It should also be noted that their energy density is relatively low, typically below 10 Wh/kg [14].

LICs, on the other hand, exhibit both high energy density (up to 100 Wh/kg) and high power density (even exceeding 10⁴ W/kg), although their power density is an order of magnitude lower than that of conventional supercapacitors [8]. Traditional supercapacitors excel in applications requiring rapid charge and discharge cycles, such as traction systems, where they capture regenerative braking energy in traction vehicles. In contrast, hybrid supercapacitors are far better suited for applications demanding higher energy density and significantly lower self-discharge rates. However, their charging and discharging processes are slower, as high current surges may damage the components. In theory, this suggests that LICs are better suited as stationary energy storage systems integrated with the power grid [15].

Further potential applications can be seen in the ongoing revolution in electromobility. The energy storage market is actively seeking new solutions, making LICs a natural focus of research for application in electric vehicles.

Omar et al. [16] demonstrated in their studies that LICs have potential applications in both BEVs (Battery Electric Vehicles) and HEVs/HICEs (Hybrid Electric Vehicles or Hybrid Internal Combustion Engine Vehicles). Research conducted across various temperatures and current conditions indicated that LICs offer better energy efficiency in charge-discharge cycles and extended lifespan, making them highly effective for fast-charging and high-discharge applications. Despite their lower

efficiency at low temperatures, LIC technology provides a favourable balance between energy density, power, and durability, offering potential benefits in BEVs, HEVs, and hybrid systems by enhancing energy efficiency and reducing traditional battery wear.

V. COMPARISON OF A HYBRID SUPERCAPACITOR WITH LITHIUM-ION CELL

1) *Operating Temperature*

LICs have a significantly wider operating temperature range compared to typical lithium-ion cells. Lithium-ion batteries can safely operate at temperatures up to approximately 50°C [16], [17], whereas lithium-ion hybrid supercapacitors can function safely at temperatures up to 70°C [18]. This capability makes them well-suited for devices operating in high-temperature environments, eliminating the need for active cooling systems or allowing for the use of lower-power cooling solutions, thereby reducing overall costs. Moreover, LICs perform significantly better in extremely low temperatures. Hybrid supercapacitors can maintain stable performance down to -30°C [17], whereas the capacity and maximum current capability of lithium-ion batteries begin to decline significantly at temperatures as high as -5°C [18].

2) *Charging Speed*

The C-rate is a parameter that describes the charging or discharging speed of an energy storage device, such as a battery, supercapacitor, or cell. It indicates how quickly the device can be charged or discharged relative to its nominal capacity. The C-rate is defined as the ratio of the charging/discharging current to the nominal capacity of the energy storage device.

$$C = \frac{I}{C_{nom}} \quad (1)$$

Where:

- I – Charging or discharging current [A]
- C_{nom} – Nominal capacity of the device [Ah]

A charging power of 1 C means that the energy storage device charges at a rate that allows it to reach its nominal capacity in 1 hour [19].

Standard lithium-ion cells are typically charged at rates between 1 C and 3 C. In contrast, LICs can charge and discharge at rates of up to 20 C without significantly affecting their lifespan [20].

3) *Power Density*

LICs have a significantly higher power density compared to conventional lithium-ion batteries. The maximum power density achievable in lithium-ion cells is limited by the time required for the chemical reactions in the electrolyte that facilitate the charging and discharging process.

The typical power density of a lithium-ion cell is around 2000 W/kg [9], whereas the typical power density of a hybrid supercapacitor is 10,000 W/kg or higher [21].

4) Lifespan

The lifespan of energy storage devices (e.g., supercapacitors, hybrid supercapacitors, and lithium-ion cells) refers to the period during which the device can efficiently store and deliver energy in accordance with its technical specifications. Cycle life is defined as the number of full charge and discharge cycles a device can endure before degradation (i.e., when its capacity drops below 80% of its initial value).

A lithium-ion cell has a maximum lifespan of approximately 3,500 charge-discharge cycles. Panasonic's NCR18650B cell is rated for about 1,000 cycles before its capacity drops to 80% of the original value [22]. LICs are estimated to last for approximately 20,000 charge-discharge cycles [23], [24]. Some manufacturers claim their LIC products can endure up to 50,000 cycles [25].

LICS are also reported to be significantly safer in operation compared to lithium-ion cells. Unlike conventional Li-ion batteries, mechanical damage, short circuits, or overcharging do not lead to the hazardous exothermic reaction known as thermal runaway—a phenomenon where a rapid, uncontrolled release of stored energy occurs due to a violent exothermic reaction. Thermal runaway is one of the major safety challenges in conventional lithium-ion cells, particularly in mobile and automotive applications.

VI. COMPARISON OF LITHIUM-ION CELLS AND HYBRID SUPERCAPACITORS FOR ENERGY STORAGE APPLICATIONS

For the purpose of calculations, the target capacity of the energy storage system under consideration is assumed to be 5 kWh. An analysis was conducted focusing on capacity, lifespan, weight, volume, and cost-effectiveness.

Certain simplifications have been made for the calculations. Battery Management System (BMS) considerations are omitted. The required shape of the energy storage system is not taken into account. The impact of heat dissipation methods on the final volume is disregarded.

Lithium-Ion Cell Parameters (1)[22]

- Nominal Capacity: 3.35 Ah
- Nominal Voltage: 3.6 V
- Energy Stored per Cell: 12.06 Wh
- Diameter / Height: 18.5 mm / 65.3 mm
- Mass: 0.05 kg
- Estimated Cost: ~4.60 EUR

Hybrid Supercapacitor Parameters (2) [25]

- Nominal Capacity: 8 Ah
- Nominal Voltage: 3.7 V
- Energy Stored per Cell: 29.6 Wh
- Diameter / Height: 45.6 mm / 94 mm
- Mass: 0.315 kg
- Estimated Cost: ~69.00 EUR

Required Number of Cells (N1 for Li-ion, N2 for Hybrid Supercapacitor) for 5 kWh Capacity

$$N1 = \frac{5000 \text{ Wh}}{12,06 \text{ Wh}} \cong 415 \text{ units.} \quad (2)$$

$$N2 = \frac{5000 \text{ Wh}}{29,6 \text{ Wh}} \cong 169 \text{ units.} \quad (3)$$

Estimated Cost of Cells for Each Storage System (P1 and P2)

$$P1 = 415 * 4,60 \text{ EUR} = 1909 \text{ EUR}$$

$$P2 = 169 * 69 \text{ EUR} = 11661 \text{ EUR}$$

Lifespan and Depreciation Cost per Cycle (KC1 for Li-ion, KC2 for Hybrid Supercapacitor)

$$KC1 = \frac{1909 \text{ EUR}}{1000 \text{ cycles}} = 1,91 \frac{\text{EUR}}{\text{cycle}} \quad (4)$$

$$KC2 = \frac{11661 \text{ EUR}}{50\,000 \text{ cycles}} = 0,23 \frac{\text{EUR}}{\text{cycle}} \quad (5)$$

Total Mass of Storage Systems (M1 for Li-ion, M2 for Hybrid Supercapacitor)

$$M1 = 415 * 0,05 \text{ kg} = 20,14 \text{ kg} \quad (6)$$

$$M2 = 169 * 0,315 \text{ kg} = 53,30 \text{ kg} \quad (7)$$

Volume Calculation for Each Cell (Lp1 and Lp2) and Total Volume of Storage Systems (L1 and L2)

$$Lp1 = \pi * 9,25 \text{ mm}^2 * 63,3 \text{ mm} = 17,59 \text{ cm}^3 \quad (8)$$

$$L1 = 415 * 17,59 \text{ cm}^3 \cong 7,3 \text{ cm}^3 \quad (9)$$

$$Lp2 = \pi * 22,8 \text{ mm}^2 * 94 \text{ mm} = 154,5 \text{ cm}^3 \quad (10)$$

$$L2 = 169 * 154,54 \text{ cm}^3 \cong 26 \text{ dm}^3 \quad (11)$$

VII. COMPARISON BETWEEN EDLC, LIC AND LI-ION

Feature	Electric Double-Layer Capacitor (EDLC)	Lithium-Ion Hybrid Capacitor (LIC)	Lithium-Ion Battery (Li-ion)
Charge storage mechanism [26][9][19]	Non-faradaic – electrostatic charge separation in electric double layer	Hybrid – asymmetric electrodes: one stores charge non-faradaically (EDLC-type), the other faradaically (Li ⁺ intercalation).	Faradaic – reversible redox reactions, Li ⁺ intercalation/deintercalation in both electrodes.
Electrode materials [27][9][11]	Both electrodes made of high-surface-area activated carbon (porous structure).	Positive electrode: activated carbon (as in EDLC). Negative electrode: prelithiated carbon (e.g., graphite or Li ₄ Ti ₅ O ₁₂).	Cathode: Li-based insertion materials (e.g., LCO, NMC, LFP). Anode: graphite, LTO, or silicon-doped carbon.
Electrolyte [9][13][21]	Organic or aqueous electrolyte (e.g., tetraethylammonium salts in acetonitrile or Na ₂ SO ₄ in water).	Organic electrolyte with Li salts (e.g., 1 M LiPF ₆ in carbonate solvents), enabling Li ⁺ transport.	Organic Li-based electrolyte (LiPF ₆ or LiBF ₄ in carbonates); may include additives or gel/solid-state variants.
Single cell voltage [10][21][25]	~2.3 V (aqueous) to 2.7–3.0 V (organic); limited by electrolyte breakdown voltage.	2.8 V (fully discharged) to ~3.8–4.0 V (fully charged), enabled by stable anode potential.	Typically 3.0–4.2 V; nominal voltage ~3.6–3.7 V depending on chemistry.
Energy density (Wh/kg) [11][24][25]	Low: typically 2–8 Wh/kg (commercial).	Moderate: 10–20 Wh/kg (standard); up to 77 Wh/kg in commercial LIC; lab-scale devices exceed 100 Wh/kg.	High: 100–250 Wh/kg (mainstream); >300 Wh/kg for high-Ni or Si-anode cells.
Power density (W/kg) [9][19]	Very high: 500–5000 W/kg typical; up to >10,000 W/kg in pulse applications.	High: ~1000–5000 W/kg; up to 9000 W/kg reported in commercial LICs.	Moderate: ~100–1000 W/kg; up to ~3000 W/kg for high-rate chemistries (e.g., LTO).
Cycle life (full cycles) [19][23][25]	>100,000 cycles; minimal degradation, often limited by electrolyte aging.	~50,000+ cycles; significantly longer than conventional batteries.	~500–3000 cycles typically; up to ~10,000 for LTO-based systems.
Self-discharge [15]	Noticeable; significant voltage drop over weeks/months.	Lower than EDLC; LICs exhibit ultra-low leakage current.	Very low; ~2–5% capacity loss per month in high-quality cells.
Cell advantages	Ultra-fast charge/discharge, extremely long life, wide operating temperature, high efficiency, intrinsically safe.	High power + moderate energy; long life; high voltage; suitable for fast-charging systems and transient load support.	High energy density, mature technology, stable voltage output, scalable for EV and grid storage.
Limitations	Very low energy density; significant voltage variation; requires DC-DC converters; poor long-term charge retention.	Lower energy density than batteries; higher cost; still emerging in commercial scale; Li supply dependence.	Limited cycle life; thermal management required; safety concerns under abuse; recycling and raw material supply issues.

VIII. SUMMARY

The initial cost of an energy storage system based on Panasonic lithium-ion cells is significantly lower at the time of purchase. However, hybrid supercapacitors offer a much longer lifespan, resulting in a lower cost per cycle. This suggests that in the long term, a storage system based on hybrid supercapacitors is expected to be more cost-effective due to its

high durability. From the perspective of weight and volume, the lithium-ion battery-based system is significantly lighter and more compact. In applications where these parameters are critical, lithium-ion cells would be the better choice. On the other hand, an energy storage system based on hybrid supercapacitors is the optimal solution when the initial cost is less important than long-term efficiency and longevity. Such a system would be preferable for applications where extended

operational lifespan and amortization over many years are the primary concerns.

From a broader technological perspective, LICs combine the fast charge/discharge characteristics of EDLCs with the higher energy density typical of batteries, filling the performance gap between both systems. These features render LICs particularly advantageous in hybrid energy storage architectures, fast-charging electric vehicles, and renewable grid-buffering applications. These properties make it a potentially groundbreaking solution in the fields of electromobility and stationary energy storage systems.

Despite encouraging research results, this technology still requires further development and optimization, particularly in terms of enhancing its market availability and reducing production costs. The potential applications of LICs span a wide range of industries, from electric vehicles to renewable energy storage systems, indicating that the continued advancement of these energy storage components could significantly impact the future of sustainable energy storage. Future research efforts should focus on improving electrode materials, particularly anodes, and developing new electrolytes that can further enhance the performance of LICs, making them even more competitive compared to traditional lithium-ion cells. This would enable fuller utilization of the potential of this technology in both mobile and stationary applications.

REFERENCES

- [1] "Consilium Europa." <https://www.consilium.europa.eu/>.
- [2] Nature Editorial, "[3] Lithium-ion must be greener," *Nature*, vol. 594, no. 7, pp. 7–7, 2021. <https://doi.org/10.1038/d41586-021-01735-z>
- [3] "portalnaukowy.edu.pl." <http://www.portalnaukowy.edu.pl> (accessed Dec. 28, 2021).
- [4] A. Lisowska-Oleksiak, A. Nowak, and M. Wilamowska, "Superkondensatory jako materiały do magazynowania energii," *Acta Energ.*, vol. nr 1, pp. 71–79, 2010.
- [5] "PRODUCT GUIDE Maxwell Technologies ® BOOSTCAP ® Ultracapacitors," 2009.
- [6] Y. Wang and Y. Xia, "Recent Progress in Supercapacitors: From Materials Design to System Construction," 2013, <https://doi.org/10.1002/adma.201301932>
- [7] Y. Firouz, N. Omar, J. M. Timmermans, P. Van den Bossche, and J. Van Mierlo, "Lithium-ion capacitor - Characterization and development of new electrical model," *Energy*, vol. 83, pp. 597–613, 2015, <https://doi.org/10.1016/j.energy.2015.02.069>
- [8] K. Leng *et al.*, "Graphene-based Li-ion hybrid supercapacitors with ultrahigh performance," *Nano Res.*, vol. 6, no. 8, pp. 581–592, Jun. 2013, <https://doi.org/10.1007/S12274-013-0334-6>
- [9] A. Jagadale, X. Zhou, R. Xiong, D. P. Dubal, J. Xu, and S. Yang, "Lithium ion capacitors (LICs): Development of the materials," *Energy Storage Materials*, vol. 19. Elsevier B.V., pp. 314–329, May 01, 2019, <https://doi.org/10.1016/j.ensm.2019.02.031>
- [10] JSR Micro, "JM Energy's Lithium Ion Capacitor: The Hybrid Energy Storage Advantage," *Thin Film users Gr. Altern. Energy Symp.*, 2009.
- [11] M. Liu *et al.*, "Emerging Potassium-ion Hybrid Capacitors," *ChemSusChem*, vol. 13, no. 22, pp. 5837–5862, 2020, <https://doi.org/10.1002/cssc.202000578>
- [12] M. Ameziane, J. Huhtasalo, L. Flajšman, R. Mansell, and S. van Dijken, "Solid-State Lithium Ion Supercapacitor for Voltage Control of Skyrmions," *Nano Lett.*, vol. 23, no. 8, pp. 3167–3173, Apr. 2023, <https://doi.org/10.1021/ACS.NANOLETT.2C04731>
- [13] Y. Cai, B. Zhao, J. Wang, and Z. Shao, "Non-aqueous hybrid supercapacitors fabricated with mesoporous TiO₂ microspheres and activated carbon electrodes with superior performance," *J. Power Sources*, vol. 253, pp. 80–89, May 2014, <https://doi.org/10.1016/J.JPOWSOUR.2013.11.097>
- [14] K. Naoi, S. Ishimoto, J. I. Miyamoto, and W. Naoi, "Second generation 'nanohybrid supercapacitor': Evolution of capacitive energy storage devices," *Energy Environ. Sci.*, vol. 5, no. 11, pp. 9363–9373, 2012. <https://doi.org/10.1039/c2ee21675b>
- [15] I. N. Jiya, N. Gurusinge, and R. Gouws, "Combination of LiCs and EDLCs with batteries: A new paradigm of hybrid energy storage for application in EVs," *World Electr. Veh. J.*, vol. 9, no. 4, 2018, <https://doi.org/10.3390/wevj9040047>
- [16] N. Omar *et al.*, "Assessment of lithium-ion capacitor for using in battery electric vehicle and hybrid electric vehicle applications," *Electrochim. Acta*, vol. 86, pp. 305–315, 2012. <https://doi.org/10.1016/j.electacta.2012.03.026>
- [17] D. Karimi, H. Behi, M. S. Hosen, J. Jaguemont, M. Bercibar, and J. Van Mierlo, "A compact and optimized liquid-cooled thermal management system for high power lithium-ion capacitors," *Appl. Therm. Eng.*, vol. 185, no. December 2020, p. 116449, 2021, <https://doi.org/10.1016/j.applthermaleng.2020.116449>
- [18] T. H. Tran, S. Harmand, B. Desmet, and S. Filangi, "Experimental investigation on the feasibility of heat pipe cooling for HEV/EV lithium-ion battery," *Appl. Therm. Eng.*, vol. 63, no. 2, pp. 551–558, 2014, <https://doi.org/10.1016/j.applthermaleng.2013.11.048>
- [19] A. Muzaffar, M. B. Ahamed, K. Deshmukh, and J. Thirumalai, "A review on recent advances in hybrid supercapacitors: Design, fabrication and applications," *Renew. Sustain. Energy Rev.*, vol. 101, no. October 2018, pp. 123–145, 2019, <https://doi.org/10.1016/j.rser.2018.10.026>
- [20] A. Du Pasquier, I. Plitz, J. Gural, F. Badway, and G. G. Amatucci, "Power-ion battery: bridging the gap between Li-ion and supercapacitor chemistries," *J. Power Sources*, vol. 136, no. 1, pp. 160–170, Sep. 2004, <https://doi.org/10.1016/J.JPOWSOUR.2004.05.023>
- [21] J. J. Lamb and O. S. Burheim, "Lithium-ion capacitors: A review of design and active materials," *Energies*, vol. 14, no. 4, pp. 1–27, 2021, <https://doi.org/10.3390/en14040979>
- [22] "Panasonic NCR18650B Datasheet."
- [23] M. B. F. Ahsan, S. Mekhilef, T. K. Soon, M. B. Mubin, P. Shrivastava, and M. Seyedmahmoudian, "Lithium-ion battery and supercapacitor-based hybrid energy storage system for electric vehicle applications: A review," *Int. J. Energy Res.*, vol. 46, no. 14, 2022, <https://doi.org/10.1002/er.8439>
- [24] "VinaTech LICs Datasheet 3.8v 250f," 2022.
- [25] R. Adolph, "SECH SA Hybrid Ultracapacitor Cell Datasheet," 2024.
- [26] S. C. Gorgulu, I. Yazar, and T. H. Karakoc, "Review of supercapacitor technology and applications," *J. Mechatronics Artif. Intell. Eng.*, Dec. 2024, <https://doi.org/10.21595/JMAI.2024.24103>
- [27] O. E. ; Eleri, F. ; Lou, Z. Yu, O. E. Eleri, F. Lou, and Z. Yu, "Lithium-Ion Capacitors: A Review of Strategies toward Enhancing the Performance of the Activated Carbon Cathode," *Batter. 2023, Vol. 9, Page 533*, vol. 9, no. 11, p. 533, Oct. 2023, <https://doi.org/10.3390/BATTERIES9110533>