

Study of a High-voltage Switching Power Supply Parameters

Boris Martemianov, Alexander Ryzhkov, and Grigoriy Vdovin

Abstract—A principle diagram of a high-voltage low-power power supply for devices comprising a microchannel plate (MCP) has been developed. A mathematical model was built according to the developed scheme for a detailed study of the operation of the power supply and the selection of the optimal parameters of its components and obtaining the best output voltages. The power supply circuit comprises a control circuit, a pulse transformer, a voltage multiplier circuit, a feedback circuit, and an input stabilizer. The input stabilizer provides the maintenance of the voltage switched in the primary winding of the transformer at a given level regardless of the voltage drop of the power supply primary source. Moreover the stabilizer provides constant voltage maintenance when the load resistance changes. (with R_{load} changing from 100 to 200 M Ω , U_{out} did not exceed 3 V).

Keywords—high-voltage, low power, power supply, microchannel plate, MCP, MCP-detector, low signal, Cockcroft-Walton, voltage multiplier, pulse generator, pulse transformer, voltage stabilizer

I. INTRODUCTION

MCP detectors manufactured by VTC BASPIK, Ltd. are microchannel plate based devices intended for the detection of weak charged particle flows and electromagnetic radiation. They do not have entrance window and are intended for operation in vacuum volume as part of analytical, measuring and scientific equipment.

Due to the high detection efficiency of the MCP input or with the help of a photocathode the detector can detect incoming charged particles (electrons, positive and negative ions), visible light, ultraviolet and X-ray radiation, penetrating nuclear radiation: proton currents, neutrons, etc. and convert them into electron avalanches that occur in the channels of the MCP. Amplified electron flows from the MCP output arrive at a metal anode or a phosphor screen or a multi-section collector of one or another type (in this case gridding as related to the object is carried out). [1].

The MCP unit consists of one, two (the so-called chevron or V- stack) or three (Z-stack) MCPs stacked on each other. The number of MCPs depends on the specific model of the detector.

Detector MCP-assemblies are widely used in different areas: medicine, biosciences and semiconductor industry; MCP-assemblies are also applied in time-of-flight mass-spectrometry for the development of new medicines, detection of such biomolecules as proteins for disease analysis, and for measuring semiconductor devices as well. They are also widely used in scientific research areas to evaluate nanostructured devices.using time-of-flight methods and experiments in accele-

This work was supported by Limited Liability Company Vladikavkaz Technological Center "BASPIK" placed in North Osetia.

All authors work in that manufactory. Boris Martemianov(e-mail: mart_opp@mail.ru), Alexander Ryzhkov (e-mail: jurodivij@gmail.com), Grigoriy Vdovin (e-mail: grifonz7@mail.ru).

rator physics including synchrotron radiation. Sensitivity in the vacuum ultraviolet (far and extreme ultraviolet) and X-ray spectra combined with "solar blindness" and the ability to transmit a spatial image make them the preferred tool for space research.

Thus, MCP detectors intended for detecting low-level radiation should be highly stable. MCP gain shall be especially stable. It is not constant in time and depends on temperature [2] and applied voltage. In view of this it is required to design a power supply source with minimal voltage ripple which shall not exceed 0.1% at the MCP and 1% at the anode (or phosphor screen).

In modern portable devices designed for recording low-intensity radiation switching power supplies are used to apply the necessary voltages. In some cases they provide supply of high-voltage pulses of different durations to the MCP and an adjustable constant voltage at the anode (screen) [3,4]. In other devices more elements are powered by one pulse transformer [5]. However each of them has a similar structure and consists of several standard parts.

A. Pulse generator (or inverter)

Its objective is to convert the constant voltage of the primary power source (for example, batteries - $U_{in} = 3V$) into an alternating signal, namely, into rectangular pulses. In the literature a two-cycle inverter is described (Fig. 1).

In [3] (Fig. 1a) the inverter comprises an oscillator (LM555) with 40 kHz oscillation frequency, an alternating current signal generator (4027), and a timer (4096) with delay time of 25 μs . The signal from the pulse generator outputs and the timer is fed to the inputs of the conjunctors (4061), which in turn enable the MOSFET transistors. Using a timer allows voltage gating at the MCP. This solution is advantageous for use with image intensifier tubes during the operation of which a strong flash is likely to occur at the photocathode. However in the case of MCP detectors gating will inhibit the detection of low-level radiation.

In [5] (Fig. 1b) a control microcircuit is used which provides output pulses fed directly to the transistor gates. In this paper a similar inverter circuit will be used.

The diagrams for connecting transistors to a transformer given below are quite well-known and are characterized by low power consumption. The problem is that our source requires the implementation of an independent voltage adjustment across the MCP.

In the above circuits voltage adjustment is possible by changing the amplitude, duty ratio of the signal from the inverter (in this case, the voltage across the MCP and the screen will change proportionally), or by switching on voltage dividers in the high-voltage power branch of the MCP which is associated with power losses.



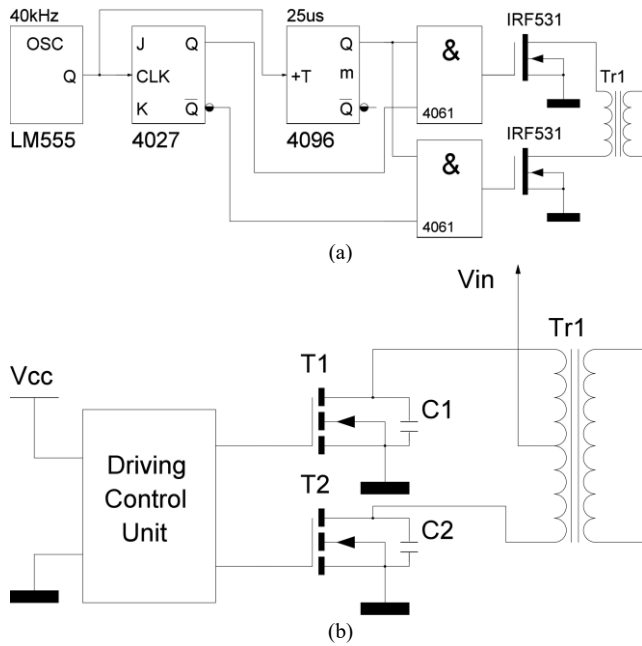

Fig. 1. Implementation of two-cycle inverters found in literature: a) – [3]; b) – [4]

B. Pulse transformer

A pulse transformer forms part of an inverter in which the amplitude of a rectangular pulse increases. In an ideal pulse transformer the pulse shape does not change, however in practical work some parasitic phenomena occur in the transformer (for example, turn-to-turn, interwinding capacitances), which lead to signal smoothing and a sinusoid of increased amplitude is fed to the output.

C. High-voltage output stage

A high-voltage output stage (multiplier) performs the functions of rectifying, multiplying and filtering the high-frequency signal picked up from the secondary winding of the transformer. High-voltage diodes and capacitors are conventionally used in these processes. However the way they are enabled varies greatly. Thus, in low-power output stages conventional voltage multipliers are used. Cockroft-Walton voltage multiplier circuit is the best known (Fig. 2) [6].

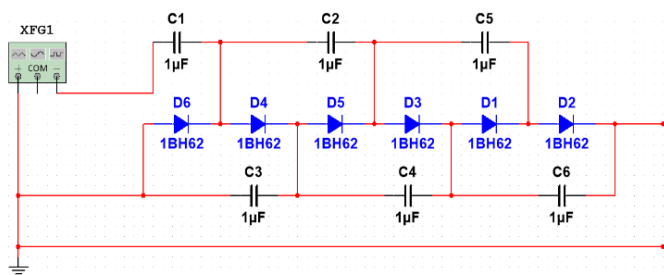

Fig. 2. Cockroft-Walton voltage multiplier circuit (circuit with capacitors in series)

D. Feedback

A feedback circuit is designed for binding input parameters to output parameters. This allows the adjustment of the input signal parameters to stabilize the output signal. Furthermore the feedback circuit provides protection against short circuit and electrical contact break. The feedback circuit can be built on the

transformer feedback winding [3]. It is used for the adjustment of the output voltage level.

II. POWER SUPPLY CIRCUIT DESIGN

Based on the above, a block diagram of the power supply is built (Fig. 3).

A schematic diagram of the proposed power supply is shown in Fig. 4. Here, the primary power supply is a stabilized voltage of 3 V. It can be adjusted manually with a resistor R_{adj} .

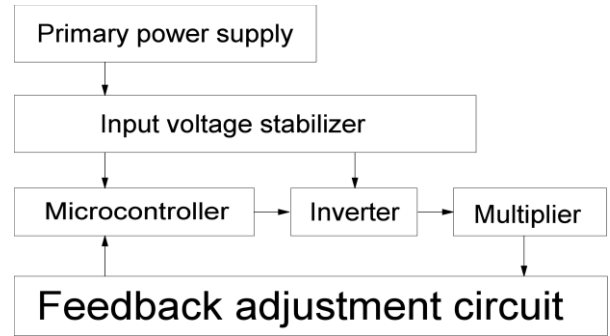

Fig. 3. Block diagram of a high-voltage power supply

Microcontroller (MC) provides rectangular pulses at the outputs with a frequency corresponding to the resonance frequency of the transformers. These pulses provide the operation of transistors VT1 and VT2 in the switching mode. They switch the zero potential of the power supply to the corresponding terminal of the input winding of the transformer (TV1 or TV2). The other terminal of the primary winding of the transformers is supplied with "+" of the circuit power supply. An alternating voltage with an amplitude in the range of 300-400 V is formed on the secondary winding of the transformers. Then it is multiplied to the required level using the diode-capacitor network (L1, L2).

Transformers TV1 and TV2 have resonance frequency 35 to 50kHz. Depending on the frequency of the input pulses of a fixed value, the voltage at the transformer output winding can be varied within wide limits. However the frequency of the incoming pulses also affects the efficiency. Therefore, in order to achieve maximum efficiency a decision was made to adjust the output voltage by limiting the power supply to the input winding of the transformers [3].

This method consists in the fact that $+U_{supply}$ is supplied not directly to the input winding of the transformer, but through the transistors (VT3, VT4) which limit the current flowing through them depending on the level of the output voltage. The transistors are controlled by the MC microcontroller.

High voltage output stage (or voltage multiplier) performs the functions of rectifying, amplifying and filtering the high-frequency signal picked up from the secondary winding of the transformer. A Cockroft-Walton circuit with capacitors in series was used (Fig. 2). Its characteristic property is that the voltage applied to each capacitor (except for the first capacitor C1) is $2.82 \times U_{ef}$ (U_{ef} is the effective value of the transformer secondary winding voltage). The voltage applied to C1 is $1.41 U_{ef}$.

Maintaining a constant voltage at the power supply input is provided by the input stabilizer circuit. The output stabilizer circuit [6] (Fig. 5) was taken as a basis and adapted for a relatively low (9 V) input voltage (Fig. 6).

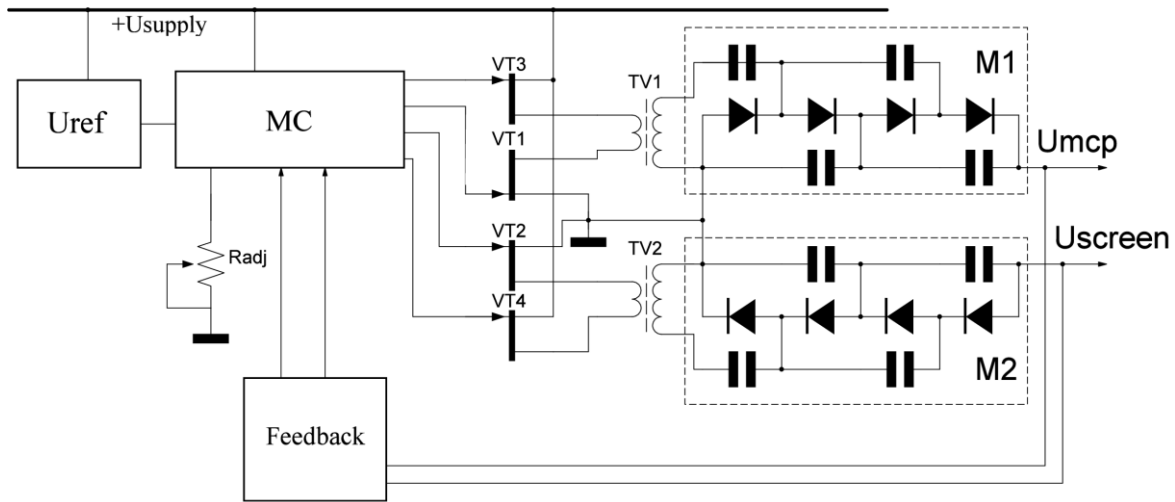

Fig. 4. Schematic diagram of the proposed power supply

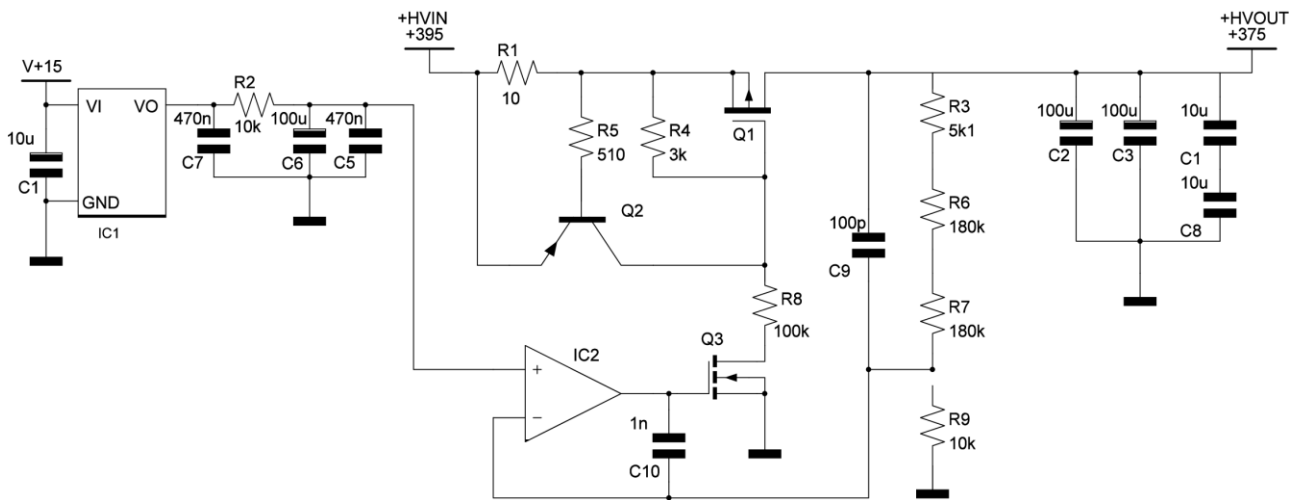

Fig. 5. Schematic diagram of the output voltage stabilizer

The stabilizer circuit comprises: reference voltage source, lowpass filter, current limiter, switching transistor, feedback circuit, output lowpass filter.

The stabilizer operates as follows. The output voltage is fed through the feedback circuit to the input of the operational amplifier and is compared with the reference voltage. The current from the input of the + HVIN stabilizer arrives at the current limiter, enables the bipolar transistor Q2 and cuts off the p-type field-effect transistor Q1. The output voltage is then fed back through a feedback circuit to the input of the operational amplifier IC2 and is compared to a reference voltage. If the output voltage falls below the specified voltage, then the operational amplifier enables transistor Q3, which leads to enabling transistor Q1 and the current flows further through the circuit. The input voltage of the + HVIN filtering circuit is initially 20 V higher than the output + HVOUT voltage, and due to this fact the voltage from the feedback circuit in the normal mode cannot be lower than the reference one. Thus it is quite sufficient to limit the voltage "from the top" with transistor Q3. In this case the output filter comprising high-capacity capacitors becomes low sensitive to short-term power interruptions and the voltage at the output of the circuit remains stable.

The feedback unit is a resistor connected in series with the load of the power supply and its resistance is selected in such a

way that at $U_{out} = U_{preset}$ (preset output voltage), the voltage across it (U_{adj}) would correspond to the reference voltage (U_{ref}). Thus when U_{out} changes, the mechanism for adjusting the voltage supply to the gates of transistors VT3, VT4 will be activated, which will lead to stabilization of U_{out} separately for the MCP and the screen. The preset voltage for the screen $U_{preset\ screen}$ is constant and equals to 3800 V, while the voltage on the MCP is set within the range $U_{preset\ MCP} = 1800 \div 2400$ V. Voltage adjustment on the MCP is carried out using a resistor R_{adj} .

For a clear demonstration of the principles of operation of a high-voltage power supply a mathematical model has been developed which includes an input voltage stabilizer, an inverter and a voltage multiplier. The electrical diagram of the model is shown in Fig. 6.

Here, the voltage of the input power supply V_{supply} passes through a stabilizer comprising a MOSFET-transistor, which acts as a key-switch, coupling the power supply to the input of the inverter briefly; resistors R1 and R2, providing cutting off transistor Q2; and also a key-switch control loop: the operational amplifier U2 compares the voltage at the output of the stabilizer (at the capacitor C6) with a reference voltage connected through a divider that simulates a system for automatically maintaining a stable output voltage using a microcontroller.

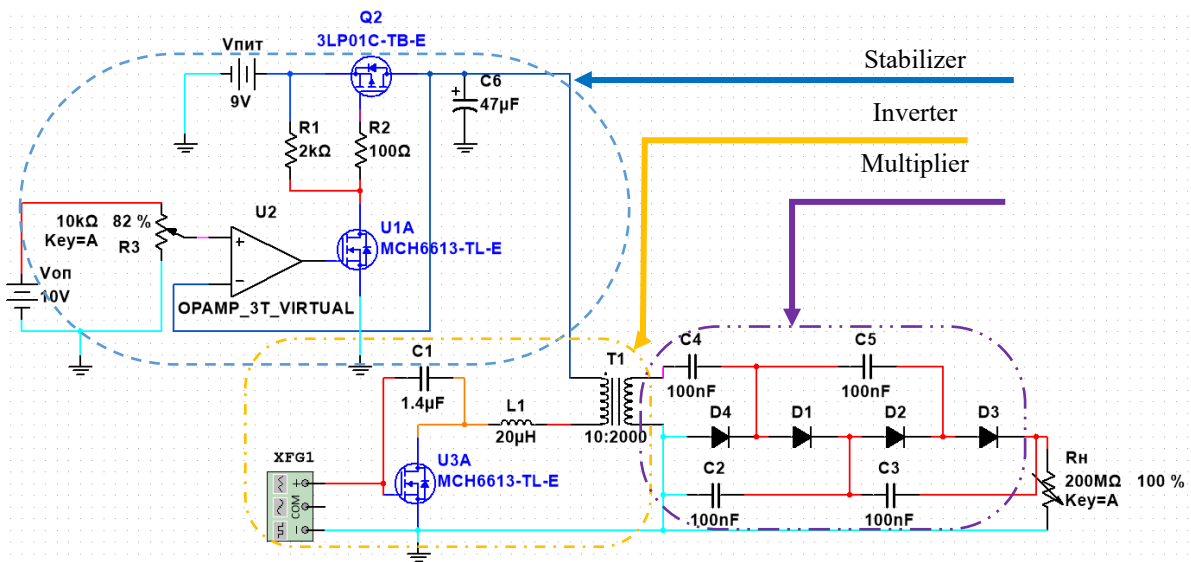

Fig. 6. Model of the power supply being investigated

If the voltage at the output of the stabilizer is less than the reference one, then the transistor U1A is opened and supplies a negative potential to the gate of Q2, thereby opening it. On the contrary, if the voltage at the output of the stabilizer turns out to be greater than the reference one, then the transistor U1A is cut off and a positive potential is applied to the gate of Q2 through the resistors R1 and R2, cutting it off.

The inverter comprises transistor U3A designed for short-circuiting the negative potential to the primary winding of the transformer T1; feedback capacitor C1 and induction coil L1 which forms a filter of rectangular pulses in the primary winding of the transformer T1. In this model the U3A transistor is controlled by the XFG1 pulse generator ($A = 5V$, $f = 50\text{ kHz}$).

Next, a two-stage Cockcroft-Walton voltage multiplier is connected to the secondary winding of transformer T1,

providing 2.85-fold multiplication of the voltage amplitude at the output of transformer T1.

III. MODELING AND EXPERIMENTS

The constructed model makes it possible to study the initial processes occurring in the power supply when voltage is applied, the influence of changes in the parameters of circuit elements on the output voltage level, ripple and load capacity.

Below are the results of a number of experiments aimed at determining such parameters as: operating range of input voltages, the influence of the load current on the operation of the power supply, dependence of the output voltage on the input stabilized voltage.

Oscillograms of the most important component parts of the power supply are shown in Fig. 7-10.

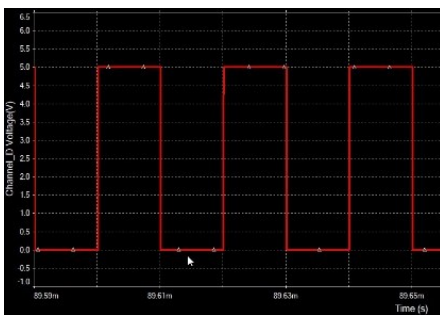

Fig. 7. Rectangular pulses ($U_a=5V$, $f=50\text{ kHz}$) arriving at gate U3A

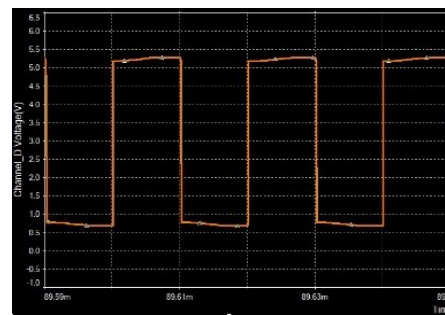

Fig. 8. Signal on the primary winding of the transformer T1

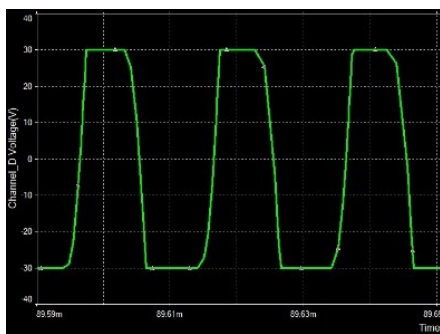

Fig. 9. Control signal at the output of the operational amplifier U2

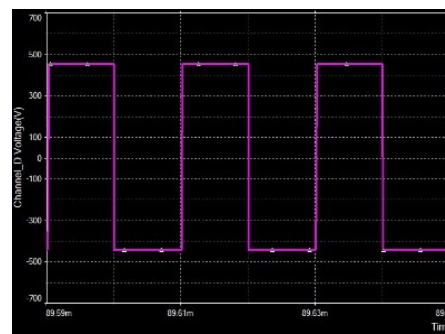

Fig. 10. Signal on the secondary winding of the transformer T1

During the positive half-wave the negative potential is pulled up to the gate of the transistor Q2 and the voltage V_{supply} from the battery charges the capacitor C6 and supplies "+" power to the primary winding of the transformer T1. And during the negative half-wave Q2 is locked and the capacitor C6 is discharged to the primary winding of T1 maintaining a high potential. The operational amplifier U2 operates in such a way as to maintain the preset voltage level at the primary winding of T1.

In the course of studying the model a range of operating voltages was defined. Fig. 11 shows a diagram of the dependence of U_{out} on U_{ref} with a load resistance $R_{load} = 200 \text{ M}\Omega$.

It was also found out that the power supply maintains the output voltage level with negligible deviations (about 3 V) when the load resistance decreases in a wide range (Fig. 12).

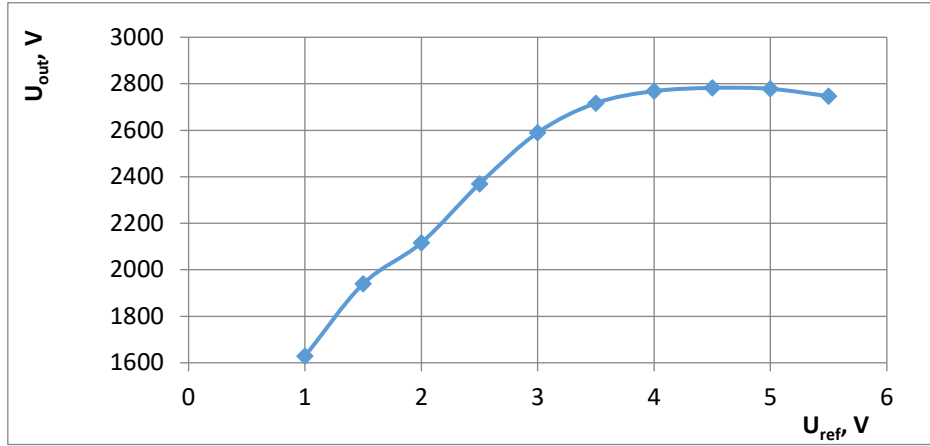

Fig. 11. Diagram of dependence U_{out} on U_{ref}

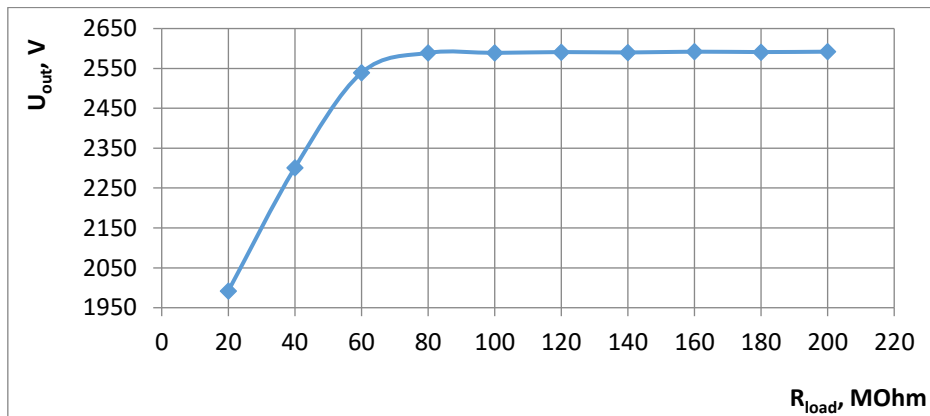

Fig. 12. Diagram of dependence of the output voltage on the load resistance

The diagram shows that the output voltage rises linearly from 1 to 3.5 V followed by a slow decline. This is due to the fact that when the reference voltage (in fact preset voltage) approaches the supply voltage level, the stabilizer cannot maintain the required voltage at the input of the transformer due to the imperfection of the elements. When the voltage is set below 1V, the inverter will not start.

As can be seen from the diagram the output voltage practically does not change with a decrease in the resistance R_{load} from 200 M Ω to 100 M Ω , and the ripple level did not exceed 200 mV at $U_{in} = 3V$, $R_{load} = 20 \text{ M}\Omega$ (Fig. 13). This is no more than 0.01% of the output voltage value. Thus, based on the simulation results such a power supply unit is capable of providing stable power supply to the microchannel plate (its resistance is considered to be about 100 M Ω).

Figure 14 shows a diagram of dependence of the stabilized voltage (coming from the stabilizer to the primary winding of the transformer) U_{st} on the value of the primary voltage source

U_{in} . This dependence shows the ability of the stabilizer to withstand the preset voltage level.

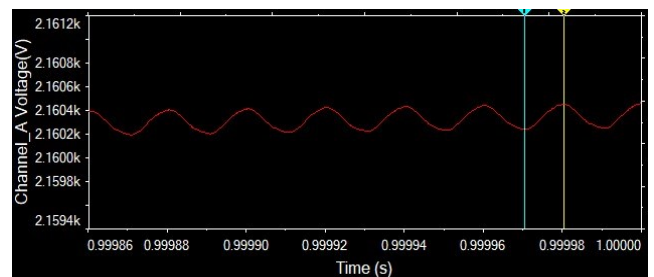

Fig. 13. Output voltage of the power supply at $U_{in} = 3V$, $R_{load} = 20\text{M}\Omega$

It can be seen from the diagram that with a slump of U_{in} down to 6 V the voltage switched on the input winding of the transformer will be unchanged.

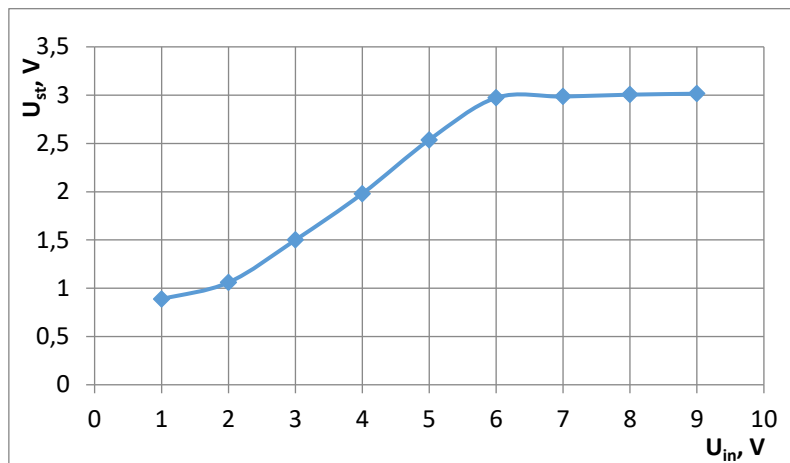

Fig. 14. Diagram of dependence of the input stabilized voltage (U_{st}) on the supply voltage (U_{in})

IV. CONCLUSIONS

The aim of this work was to develop a schematic diagram of a power supply unit for devices that include microchannel plates (in particular, MCP detectors), as well as to design a mathematical model for studying the regularities of the operation of a high-voltage power supply unit and selecting optimal values of components to achieve the required output voltages.

The constructed model makes it possible to empirically study the processes occurring in the component parts of the power supply unit, to find the most suitable parameters of the elements relying on particular tasks.

The feature of the developed circuit is the use of a voltage stabilizer that eliminates the influence of the input voltage drop on the magnitude and level of the output voltage ripple. So the stabilizer provides a constant voltage supply to the primary winding of the transformer when the input voltage drops from 9 V down to 6 V. Also, thanks to the stabilizer, the output voltage is supplied with high accuracy: voltage ripple does not exceed 0.01%.

The operating input voltage range for this power supply configuration is 1 to 3.5 V. By changing the preset voltage within these limits it is possible to adjust the output voltage to ensure its stability with a strong change in the level of load resistance that goes beyond the lower limit of 100 M Ω .

REFERENCES

- [1]. Rosanna Rispoli, Elisabetta De Angelis, Luca Colasanti, Nello Vertolli, Stefano Orsini «ELENA microchannel plate detector: absolute detection efficiency for low energy neutral atoms», *Optical Engineering*, 2013.
- [2]. O. Chassela A. Grigoreiv A. Fedorov N. André, «Resistance and gain of the microchannel plate (MCP) detector as a function of temperature», *International Conference on Space Optics—ICSO*, 2018.
- [3]. J UPADHYAY, H R BUNDEL, R CHANDRA, J A CHAKERA, C P NAVATHE and P D GUPTA, «A simple power supply and control unit for pulsed operation of a microchannel plate imaging detector», 1998.
- [4]. ZHI Qiang, YANG Ye, YAN Bo, LI Jun-guo, NI Xiao-bing, WANG Yu, YAO Ze, «The Cathode Control Circuit Design of Auto-Gating Power Supply for Low-Light-Level Image Intensifier», *Science and Technology on Low-Light-Level Night Vision Laboratory*, Xi'an, China, 2015.
- [5]. Chengquan Peia, Jinshou Tianb, Zhen Liua, Hong Qinc, Shengli Wua, «A novel ZVS high voltage power supply for micro-channel plate photomultiplier tubes», 2017.
- [6]. Cristian H. Belussi, Mariano Gómez Berisso, Yanina Fasano, «Low-noise High-voltage DC Power Supply for Nanopositioning Applications», 2014.