

Rotary Telemetry System for Temperature Measurements in Aircraft Component Testing

Tomasz Kabala, Jerzy Weremczuk

Abstract—Aviation testing is intrinsically connected with rotary telemetry, which enables engineers to measure and verify parameters of high-speed aircraft engines components during laboratory testing. The main purpose of this article is to propose new design concept of smart telemetry module for temperature measurements, which could be easily adapted to various demands of high-speed rotary components tests and is more handful, functional and affordable than other solutions on the market. The result of the work is a telemetry system in form of light weight, PCB-based, wireless powered, smart transducer. Article presents state of art analysis, design and manufacturing steps, test results and conclusions.

Keywords—telemetry; electronics; measurements, smart sensors; laboratory testing; aviation

I. INTRODUCTION

THE aviation world places great emphasis on the durability and reliability of high-speed rotary components e.g. high speed bearings and shafts, because failure of these aircraft engine parts can initiate a cycle of events leading to a catastrophe. Testing and certification of new types of rotary components in laboratory, before usage in aircraft, is extremely important and increases safety of flying [1]. Telemetry systems give engineers chance to look inside processes which take place inside aircraft engine and to understand them better [2]. There are a lot of types of rotary telemetry in terms of: transmission medium, types of transmitted signals, power source and speed performance. Typical telemetry system, which is used in aviation laboratories, consists of transmission module connected to rotary part of test head and receiver module installed on a stationary part of test rig. Data between these two sections are transmitted wirelessly thanks to in-built transducers and transmission modules [3]. Standard rotary component tests could be divided into two main groups: endurance tests and performance tests. During endurance test engineers simulate thousands of cycles with take-off, cruise, ground idle and landing conditions to check the durability of rotating parts [1]. In performance test the goal is to find the limits of components by simulating extreme conditions. In both types of tests one of the most useful and important parameters is temperature of rotary modules e.g. temperature of main shaft bearing rotary race. In aviation testing durability

and robustness are very important so in most cases engineers use thermocouples in test head instrumentation. Thanks to their small sizes and various shapes, they could be installed directly on the surface or inside tested component. Wireless temperature measurements with use of thermocouples make it necessary to process and condition the signal at the level of rotary section of telemetry system [5], [6]. The computational and communication functions make the telemetry module an example of a smart measurement transducer [7], [8]. In comparison to measurements with use of multichannel slip ring, based on brushes which is rubbing the contact disc, smart telemetry systems are more functional and durable. Accuracy of the system could be increased by reading, conditioning, and processing signal near the test article, which is important during measurements certification process [3], [4]. Moreover, additional smart functionalities like in-built data processing algorithms, signal conditioning and alarm level monitoring give engineers strong item to investigate processes more closely. Rapid growth of IoT and WSN technology in last decade brings bunch of new communication techniques and electronic design possibilities, which was not available before and open a new area for telemetry system designers. Therefore, smart measurements will help to make a step on the way to transform aviation laboratories in the direction of Industry 4.0, as it is observed in other industries [9]. Unfortunately, most of high-speed rotary telemetry systems that could transmit temperature signals are complicated and very expensive. There are cases where telemetry module is more expensive than all other test equipment in total and sometimes it's out of test budget. There is a lack of simple, universal and handful telemetry systems on the market, that could be used both in long complicated test campaigns and simple checks of component parameters. The main motivation of this paper is to propose design concept of smart telemetry system that could be more affordable, handful and could simplify way of rotary component testing. The goal of the design work was to prepare a functional prototype of telemetry system with use of selected components and techniques. Following sections of article show the decision process which was the effect of research in field of rotary components testing, modern microcontrollers, communication protocols, smart measurements, power supply techniques and PCB design. In the final phase of research the prototype was tested in Łukasiewicz Research Network - Institute of Aviation. Tests involved simulation of real rotary test conditions in terms of rotational speed, temperature, and sensor placement.

T.Kabala is with Łukasiewicz Research Network – Institute of Aviation, Poland, (e-mail: tomasz.kabala@ge.com).

J.Weremczuk is with Faculty of Electronics and Information Technology, Warsaw University of Technology, Poland (e-mail: jerzy.weremczuk@pw.edu.pl).



II. METHODS

The commencement of design work was preceded by an in-depth state of art analysis in field of aviation testing and modern electronics what is described in the following sections.

A. Design requirements and general concept of the system

The main purpose in the first part of the research was to collect design requirements that will represent desired parameters of telemetry system for typical aviation rotary tests. Literature research combined with nearly ten years of the author's experience in components testing allowed to collect presented project requirements (Table I).

TABLE I
DESIGN REQUIREMENTS

No.	Design requirements	Source of requirement
1	Ability to work up to 20000 rpm.	Many of jet engines component have to be tested at high rotational speeds.
2	Low weight and easy to balance.	Unbalance at high speed could cause high forces influencing on test rig and test article.
3	Easy installation and reinstallation.	There are cycles of test head assembly and disassembly in some test campaigns to check the degradation of test article or to change test configuration.
4	Flexibility of the stationary receiver module placement	Due to various test head shapes and dimensions stationary part of telemetry module shouldn't need complicated placement and alignment.
5	High resistance to vibrations and centrifugal forces.	All rotary components of telemetry module must be resistant to increased vibration levels and high centrifugal forces. Disconnection of any component during operation may result in a dangerous accident.
6	Ability to work with multiple thermocouple channels.	Thermocouple are the most popular sensors in the rotary test heads instrumentation. Rotary modules have to offer CJC (Cold Junction Compensation) for operation with thermocouples.
7	Power source must be able to work for years without interruption.	Some of endurance tests could take more than a year of 24/7 testing.
8	Low cost	Low cost of telemetry module will make it possible to test more components which will increase the safety of flying.

The goal of the second part of the preliminary research was to propose technical solutions which will best suit described demands of rotary component tests and to formulate basic plan of the system structure and implementation. As a research result, telemetry system in form of light weight, wireless powered, PCB based, smart transducer was proposed. Single PCB design approach simplifies the system and makes total cost of the system lower, but it needs special attention in manufacturing process. Wireless transmission of the power helps to build durable and easy to use telemetry system that could be used for years. The performed research made it

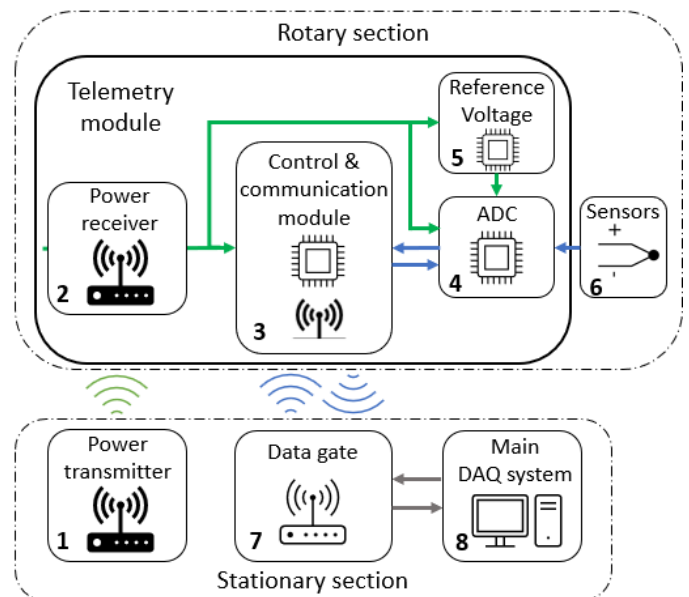

Fig. 1. Basic structure of designed telemetry system

possible to formulate preliminary design assumptions and prepare basic plan of telemetry system implementation (Fig. 1). All circuits in designed telemetry system are powered by power transmitter (1), which interacts with power receiver (2). Measurements and data transmission are managed by control and communication module with integrated microcontroller (3). Data measurements are performed by ADC (4) which is connected to reference voltage source (5). Signals acquired by sensors (6) are transformed to digital form and transmitted through serial interface to a control unit, where they are processed and sent to data gate (7). Accessibility of data in main DAQ system (8) is realized by wire communication. Implementation of design concept that was shown above needed an in-depth analysis of wireless communication techniques, measurements and power transmission. In all of these sections study of electronic component possibilities had to be performed. Works described in following chapters realize presented basic idea of the telemetry system and show design and decision process.

B. MCU and wireless communication

MCUs (Microcontroller unit) predestinated for wireless communication are the fundamental build blocks of devices used in IoT and modern WSN networks, where thousands of nodes could communicate each other [10]. In recent years, there has been dynamic development in these areas, especially in field of low power communication modules. Some of them needs only power connection to make a communication available. That approach simplify design in comparison to classic approach where each element had to be chosen by the designer. Due to the need of reduction in space and weight of the system, while ensuring a strong and simple assembly, the WE Proteus III module with castled edges was chosen. In designed telemetry system integrated MCU is used not only for communication but also as a main

control unit of the system, which controls measurements performed by ADC and process the data. Selected module use nRF52840 microcontroller which is built around the 32-bit ARM® Cortex™-M4 CPU with floating point unit running at 64 MHz and access to 1 MB Flash and 256 KB RAM [11]. That strong configuration of parameters makes ideal basis for smart telemetry system. For years the improvement of modules are driven by development of Low Power communication protocols like Bluetooth LE, Thread, ZigBee and ANT. Design was focused on Low Power communication protocols because they enable to extend the range of application and hence flexibility of telemetry module placement. Many of communication modules, including selected module, can work with few different communication protocols without hardware changes. During literature studies some of low power protocols were compared, considering requirements of laboratory testing (Table II).

TABLE II
COMPARISON OF LOW POWER WIRELESS COMMUNICATION PROTOCOLS.

	ANT	ZigBee	Thread	Bluetooth LE
First launched	2004	2003	2015	2010
Frequency band	2.4 GHz	868/915/2400 MHz	2.4 GHz	2.4 GHz
Max data rate	60 kbit/s	250 kbit/s	250 kbit/s	2 Mbit/s
Range	30 m	100 m	100 m	100m (over 1 km in Long Range mode)

Research shows that BLE (Bluetooth Low Energy) is currently one of the fastest growing communication protocols and it will suit requirements of rotary temperature transducer in terms of data rate, range and power consumption. Looking at ANT, ZigBee and Thread the max data rate could be too low for future upgrades of the telemetry system and multichannel measurements [13, 14]. However, it should be noted that in some cases one of these networks may be more suitable. BLE is intended to work with reduced power consumption in comparison to Bluetooth in classic version without reducing the communication range. LE and classic version of Bluetooth are not compatible but could be supported by one device. Both standards use the same ISM frequency band, but BLE uses different modulation and decreased number of channels. There are 40 2-MHz channels instead 79 1-MHz channels which are used in Bluetooth classic. Three of them are used for advertising, rest are used for general purpose of transmission. BLE mitigates the risk of collision with other networks by technique called adaptive frequency hopping. Set of communication channels are changed periodically to minimize probability of blocking the transmission [14], [15]. Adaptive form of frequency hopping algorithm means that special list of channels quality is constantly updated by the devices. In the effect only channels which are working well are used for transmission. That functionality is very interesting from the aviation laboratories point of view, because most of test rigs

are in the range of Wi-Fi networks and there could be some sources of electromagnetic noise. Generally, bidirectional communication in BLE standard starts between peripheral and central device. Peripheral device sends advertising packets and wait for central response in form of connection request. Only central device can initiate connection. When connection is established devices get new roles of client and server. Client is a device which sends requests for data to the server, which could accept the request and send the data in the response. Data on the server are structured in characteristics which represents a data value and services which are collection of related characteristics. The server could send data on its own in form of notifications and indications, when value in the database changes, but first client must request these features [14], [15]. One of the main upgrades in comparison to Bluetooth classic is new way of devices assignments, called bounding, which enable fast and simple reconnection of devices. In bounding process, the information from the pairing process is stored on the devices, so the pairing process doesn't have to be repeated in every reconnection. Typically, devices in BLE spend most of time in energy safe or power off state, after which they perform measurements and send results in configurable cycles [16]. In designed measurement system telemetry module plays a role of peripheral device that is communicating with central data gate in time periods determined by the timer settings. Connection could be reestablished automatically without the action of user. System simulates the serial port over BLE with use of notifications, what is described in chapter F.

C. Measurements

Reliable measurements performed by rotary telemetry systems are important issue of aircraft component testing. The most popular temperature sensor types in rotary engine parts testing are thermocouples. As it was introduced in chapter A, telemetry system for aviation testing should offer compatibility with these types of sensors. In order to find circuits which meets presented requirements the review of low power ADC (Analog to Digital Converters) was performed. ADC converts physical signals to their digital representations and enables system to process the data in digital form [17]. Nowadays microcontrollers units have in-build ADCs but many of them are not designed for high precision measurements. Typically, when accuracy of measurement is crucial, designers use external ADCs and high precisions reference voltage sources in form of another chip unit. Most of ADCs send the data to the MCU through serial interfaces like SPI or I2C, which offers fast and reliable communication. Research shows that there are many ADCs with features that are optimized for sensors, offered by Maxim, Analog Devices, Texas Instruments, and other semiconductor companies. One of the most interesting solutions on the market, which was selected for designed telemetry system, is MAX11410 (Fig. 2). It is a 24-Bit Multi-Channel Low-Power ADC which could work with 1.9ksp/s and offer programmable gain amplification of signals. This ADC could operate both with thermocouples and RTDs, which simplifies CJC (Cold Junction Compensation) in case of operation with thermocouples. It offers several integrated features

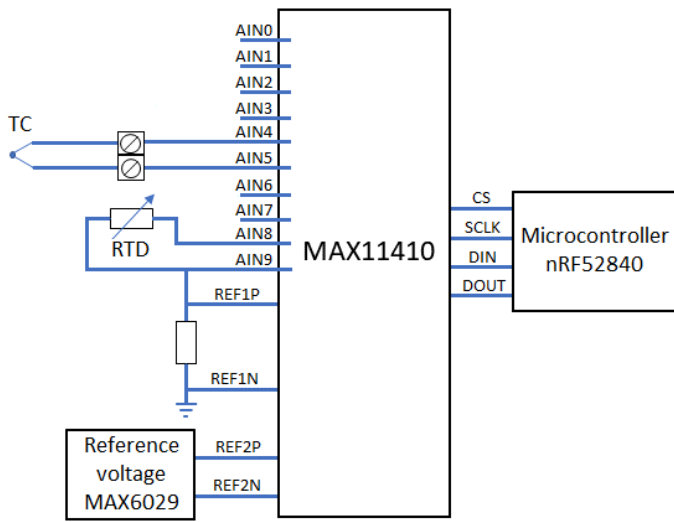

Fig. 2. Simplified application diagram of MAX11410 for operation with CJC compensated thermocouple

which facilitates precision measurements e.g. current sources providing excitation for RTD, broken wire detection, signal filtration and support for external reference resistor and voltage source. Data and control register could be accessed through SPI compatible interface [18]. The designed telemetry system involves two such ADCs to provide precise operation with 8 thermocouples (Fig. 3). CJC (Cold Junction Compensation) is implemented with use of RTD sensor, which is installed on the PCB near sensor connection pads. To operate with MAX11410 reference voltage source has to be used. In the designed system, this role will be played by MAX6029 due to very low energy consumption [19]. All thermocouple voltage measurements are referred to that level of voltage. Full digital resolution of ADC corresponds to value of reference voltage. In typical measurements of resistance MAX6029 is not used because all voltages measured across RTD are referred to voltage on reference resistor. The same current flow through measured resistor and reference resistor, so the value of current is not important and could be changed in the control register. In designed system both resistor are heated so the measurement scale had to be prepared during test of module in a heater. Calculations necessary to perform measurements with RTDs and thermocouples are explained in chapter F, and are based on comparison of measured and reference voltage.

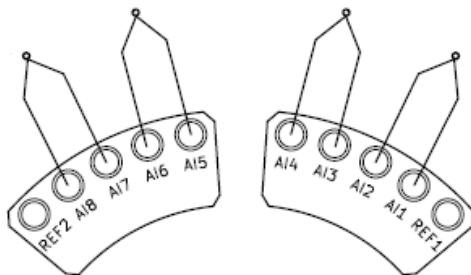

Fig. 3. Example of thermocouples connection to the telemetry module (2/4 connector groups)

D. Wireless Power Transfer

Typical rotary telemetry systems available on the market are wireless or battery powered [3], [4]. Battery powered telemetry is the simplest one, but it could be used in long terms tests only with low measurement frequencies due to limited battery capacity. Moreover, battery powered systems have problems with resistance to vibrations and centrifugal forces that could reduce overall performance of the system. Wireless powered telemetry could offer higher durability and resistance to harsh environmental conditions during component testing. Wireless Power Transfer is well known from years and has its origins in the 19th century [20]. In the last decade, WPT technology has developed significantly as a result of its use in consumer electronics and wireless sensors. There are several ways to transfer energy wirelessly [21], as it was introduced in Fig. 4.

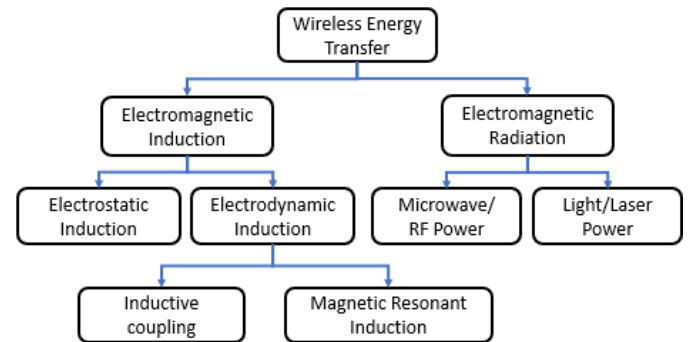

Fig. 4. Examples of wireless power transfer technologies

Far-field methods of energy transfer based on scavenging energy from electromagnetic radiation in the RF or microwave spectrum could have great effects in Low Power sensor nodes working with low sampling frequencies, due to long range and flexibility of sensor placement. These solutions could be used in aviation telemetry but mostly in the network of sensor nodes transmitting several measurement channels. Possibilities of supplying sensor nodes with intentional RF source will be investigated in future research. Technology selected for designed telemetry system have to be easily scalable to tens of inputs and outputs channels to meet various demands of aircraft component testing, so the design was focused on power transfer with use of electromagnetic induction, which is popular method in aviation rotary telemetry. Energy is transferred between transmitter and receiver coil through the maximum distance of several centimetres depends on coil size and specific methodology. Low power design of telemetry module extend the range of telemetry system which simplify the application on the test rig, so it has been recognized as one of the design goals. In last years several standards of wireless energy transfer have been developed. The most popular is Qi standard, based on inductive coupling, which could transfer 30W of power with low speed data transmission used for optimization of energy transfer [22]. There are attempts to improve Qi standard capability for charging household appliances up to 2,4 kW. Another emerging standard is AirFuel which use both RF waves and magnetic resonance depends on the distance between transmitter and receiver module [23]. There is also

the possibility of using non-standardized energy transfer with use of low-cost set of transmitter and receivers. This option was chosen for designed telemetry system, because it simplify the project which is important in the prototype phase. Selected

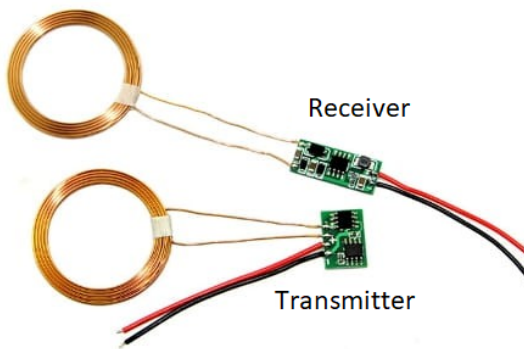

Fig. 5. Power transfer system used in telemetry module

set of power transmitter and receiver (Fig. 5) is capable to transfer 2 W (3,3 V, 600 mA) when the distance between coils is 1 mm. Voltage on the receiver output is constant up to 20 mm. Power on the output is decreasing with the distance, but is sufficient for designed telemetry module in the entire range of constant voltage.

E. PCB design and components assembly

All solutions selected in points B-D had to be organized in form of PCB design (Fig. 6) taking into account specific requirements of electronic components and their mutual relations. Works were performed in KiCad open-source software which facilitated the design process of schematic and PCB. Telemetry module was designed as a replacement of slip ring, which is used in Component Test Laboratory, so it has similar diameter and use the same mounting holes. Sensor wires are going through the holes from back side of PCB to the contact pads on the top. This solution offers firmly and convenient wire routing through ball-bearing support which was a part of slip ring equipment. The design had to consider the need of telemetry module balancing with all installed components. Therefore, one of the design goals was even

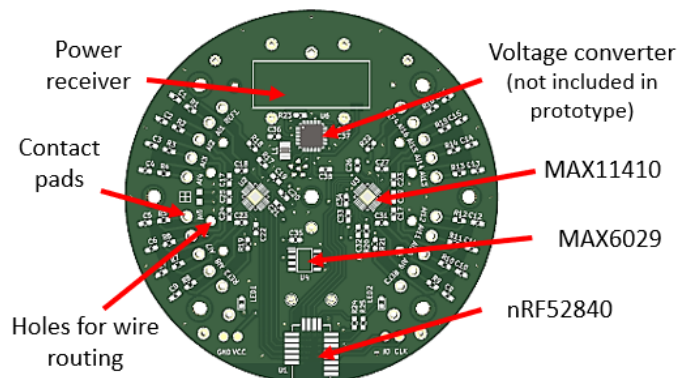

Fig. 6. Main PCB design

distribution of elements on PCB. Steel stencil for soldering paste distribution was ordered with a PCB to facilitate manual installation process. Components were placed manually in the place of footprints that were covered by solder paste through a stencil. All components are soldered in the reflow process and additionally fixed to PCB by a glue. Firmly montage is important because of high centrifugal forces and vibrations which affect every element. To ensure the durability of the system second disc with grooves, which mirror the placement of components on the PCB, was added to the design (Fig. 7). Additional disk was connected to the PCB by soldered steel

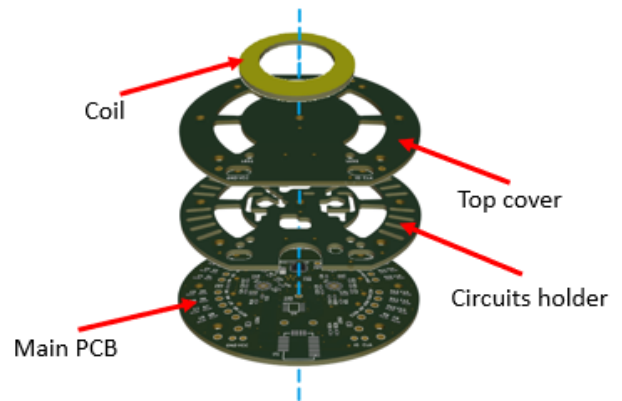

Fig. 7. Simplified telemetry module assembly sequence

bars and adhesive. Glue fills every groove to stabilize elements after connection of discs. Only contact pads are visible after joining through milled open areas. Telemetry module was initially balanced on the static manual balancer. Final dynamic correction was done with use of balancing system, because high level of balance accuracy is needed. Additional mounting disc also plays the role of electromagnetic shield which reduce the noise and separate circuits from alternating electromagnetic field generated during power transmission. In future the design will be changed to 4-layers PCB which will increase the resistance for electromagnetic noise. The final effect of the assembly is presented in Fig. 8.

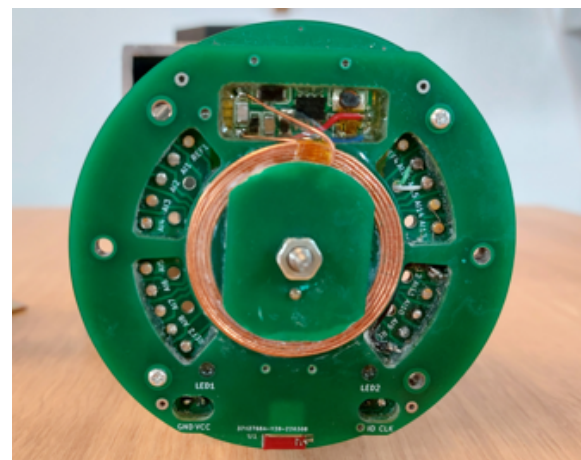

Fig. 8. Telemetry module after final assembly

F. Programming

Smart transducers are devices which offers additional functionalities in terms of communication and data processing [7]–[9]. To implement these features in manner that best suits specific application smart systems should be programmable. Segger Embedded Studio, which is free of charge for programmers who use Nordic Semiconductor MCUs, was used for implementation of program in C language. Telemetry module was programmed through contacts pads and spring programmer connectors, which were in contact during programming process. This solution offers easy actualization of software, even after installation on the test rig, which simplify testing of prototype. The program was built on the basis of BLE UART example which is distribute with software development kit shared by Nordic Semiconductor. Template consist of two programs for peripheral and central device which are connecting together. Both programs use soft device, which is a firmware used for BLE stack implementation [24]. Soft device must be copied to a certain area in the memory from an additional file. Programs emulate serial port over BLE. There is one service called NAS (Nordic UART Service) with two characteristics (RX and TX) used to transmit and receive the data. In the beginning of the operation peripheral device starts advertising. At the same time central device is in scan mode. When the communication is established, devices take the roles of client and server. The telemetry module takes the roles of peripheral device and server which is sending the data to the central device by notifications (Fig. 9). In initialization phase programs configure not only BLE but also SPI, ADC, UART and timer. When all peripherals are configured, and communication is established program sends to ADC command to start measure through SPI interface. Measurements from type K thermocouples and RTD are stored in variables for further processing. It's possible to measure temperature on RTD only by comparison to reference resistor installed on PCB, but both resistors warm up and change resistance during testing so the specific scale was build during tests in heater. To use that value for compensation it have to be transformed to voltage of the hypothetical thermocouple with the same temperature as RTD, which is installed near contact pads. It is possible with use of polynomial shown in equation equation 1 which is widely available with coefficients for various types of thermocouples .

$$E = \sum_{i=0}^n C_i (t)^i + \alpha_0 e^{\alpha_1 (t-126.9686)^2} \quad (1)$$

$$t = c_0 + c_1 E + c_2 E^2 + \dots C_i E^i \quad (2)$$

where:

t - temperature, E - voltage, $C_i, \alpha_0, \alpha_1, c_i$ - coefficients

Next to get a temperature on thermocouple, voltage is measured by comparison to high accuracy voltage reference. In following step, voltage which corresponds to reference RTD is added to voltage calculated for hot junction of

thermocouple. Final temperature is calculated by equation 2 which performs inverse polynomial. Temperature values calculated for every channel are sent wirelessly to client and next to main laboratory computer through UART. Between measurements cycles program waits for timer interrupts in sleep mode, to reduce power consumption. Low power system design helps to extend the range of wireless power transfer. In case of disconnection communication could be re-established automatically without the action of user, thanks to bonding process which was performed in the beginning of system run.

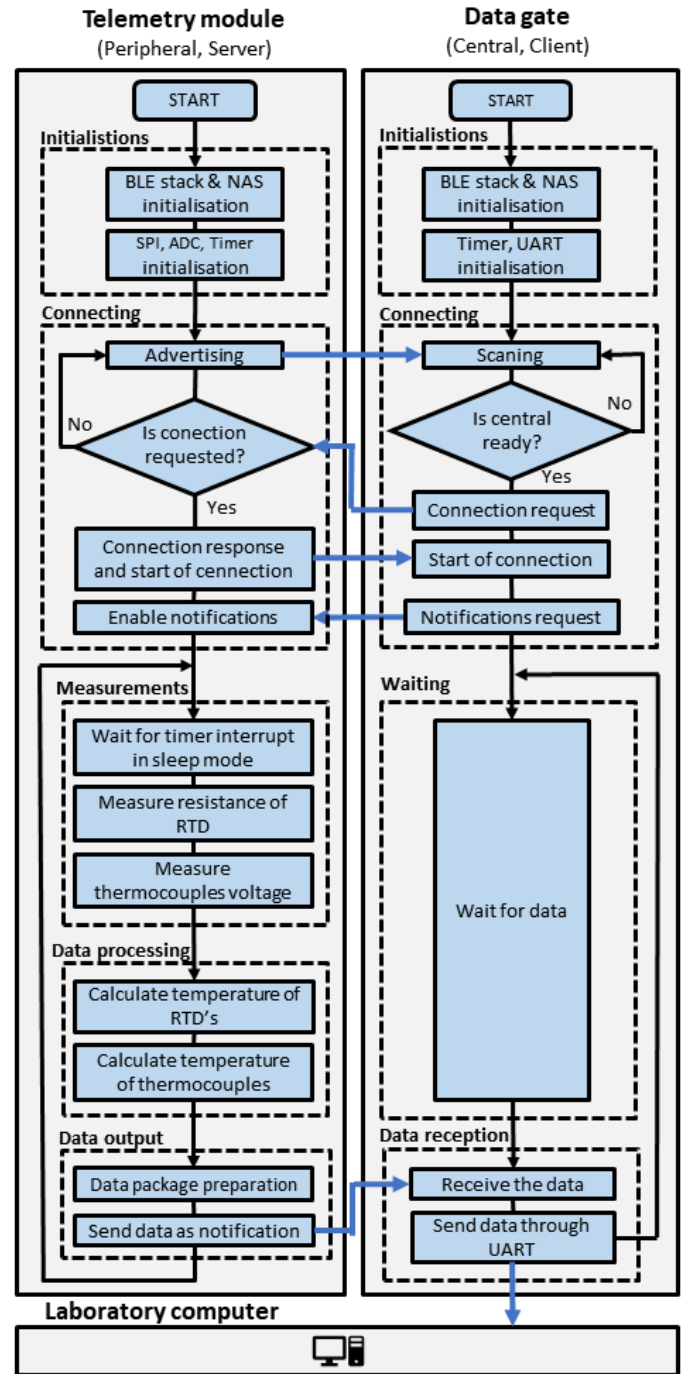

Fig. 9. Block diagram of measurement program

III. RESULTS AND TESTING

When the construction and programming works were completed, the tests of the telemetry module had begun. Preliminary tests were performed without rotation to prove basic operability of the system in stationary conditions in terms of wireless communication, measurements and power transmission. First test of the module was performed in the heater (Fig. 10 and 11) to prove the operability of RTD installed near contact pads, which is important during measurements with use of thermocouples. Temperature of the telemetry module



Fig. 10. Test of RTD installed on PCB

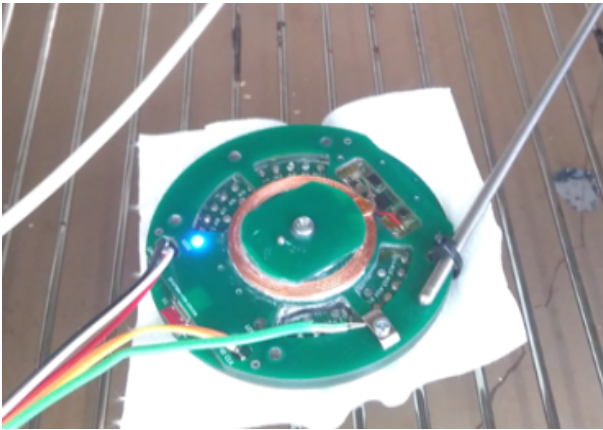

Fig. 11. Telemetry module in the heater during RTD test



Fig. 12. Test with thermocouple installed in reference heater

was increased up to 70°C. Reading from RTD installed on board are compared with reference RTD and reference thermocouple temporary installed on the surface of the board. The RTD temperature scale was build during that test to achieve high accuracy of the system and avoid effects of changes in the characteristics of other electronic components. Second test was performed with thermocouple installed in reference heater and connected to telemetry module (Fig. 12). All channels also have been checked by the thermocouple simulator. When all stationary tests were passed, operability of the system had to be proved during rotation so the test rig was prepared (Fig. 13 and 14). Telemetry module (1) was installed on the shaft of electric motor (2) with thermocouple (3) connected by a tape to the motor shaft. The temperature of the shaft could be changed by the air heater (4) and it could be measured by contactless temperature sensor (5) for a reference. The system is powered by the transmitter module installed on a moving cart (6). Speed sensor (7) and vibration sensor (8) connected to DAQ (9)

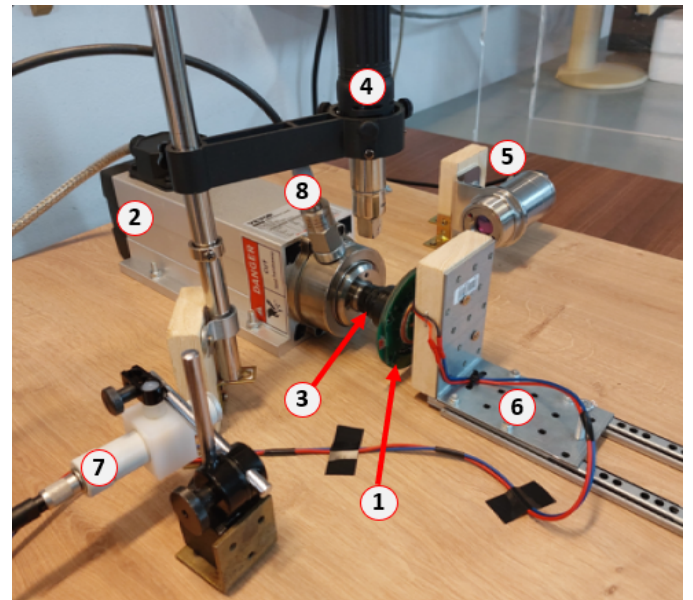

Fig. 13. Test rig configuration (part 1/2)

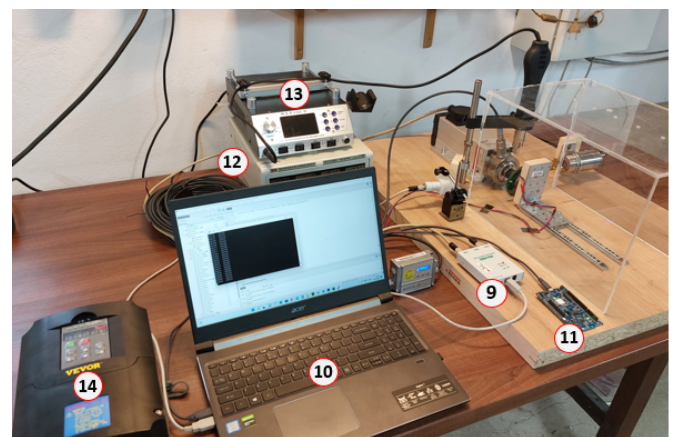

Fig. 14. Test rig configuration (part 2/2)

are components of dynamic balancing system, which have to be used during preparation of the module for higher speeds. Software for balancing is installed on a main computer (10). Data from telemetry module are received wirelessly by the data gate (11) which is connected by wire communication to main computer and shown in the terminal software. Transmitter module and contactless temperature sensor are powered by DC power supply (12). Temperature is controlled by heater control station (13). Rotational speed of electric motor could be changed by the frequency inverter (14), which could be controlled remotely for assuring safety of operator. During test all rotary components are covered by the transparent safety cover to stop them after potential disconnection. The test consisted of increasing the speed in steps of 1000 rpm with slow acceleration. Two different temperature setpoints were tested on every speed step to prove accuracy of measurements. System was tested without dynamic balancing up to 6000 rpm. For higher speeds dynamic balancing had to be performed. Thanks to balancing system the vibration level was reduced easily by change of mass in the indicated placement. The system measures level of vibration and phase shift between amplitude peak and 1/rev signal to find mass and angle of correction. Final test results of telemetry system show operability of the module up to 20000 rpm, which is enough to cover the range in most of aviation tests (Fig. 15). The different rise time of temperatures measured by contactless temperature sensor was the effect of placing the thermocouple between shaft and installation tape. After stabilization, both measurements show a similar value of temperature with the inaccuracy below 2°C which confirms the operability of the system. During test, it was checked that in the area of the test room (50m²) data gate could be located at any distance from centrally located transmitter. The measurement frequency was set to 10Hz, but it's not the limit of the system. The sampling limit depends on ADC capabilities and BLE data rate.

IV. CONCLUSIONS

This paper proposes a new approach to the design of smart telemetry systems for aircraft component testing. Proposed solution is more handfull and affordable than other solutions on the market which could simplify rotary component testing and increase safety of flying. Following sections briefly show the results of research in field of wireless communication, wireless power transmission, measurements and PCB design. The main conclusion from literature is that the rapid development of IoT and WSN in recent years offer new more efficient technologies which enable constructors to change approach to the design of rotary telemetry. The combination of Low Power communication modules integrated with MCUs, Low Power ADCs optimized for use with sensors and energy-saving communication protocols like BLE, creates perfect conditions to build functional telemetry system and extend the range of wireless power transfer. These design solutions brings new possibilities for remote measurements in aircraft component testing. In comparison to slip ring systems the biggest advantage is higher durability. Telemetry systems could work for years without interruption, so it's convenient for multichannel long-term endurance testing. Proposed design approach could be easily adapted to meet various requirements of aviation testing by changing type of ADC and simple rearrangement of PCB. Implementation of smart functionalities in telemetry module gives simplified communication and data processing possibilities, which facilitate overall configuration and calibration process of measurement paths. From mechanical point of view PCB module could be designed as a part of test rig with use of existing fittings. Designed prototype of telemetry module could be used as a replacement of slip ring that is used in the laboratory. It has 16 measurement channels and built-in RTD sensor used for compensation during measurements with thermocouples. Data are processed by microcontroller according to implemented software and sent through Bluetooth Low Energy to the data gate. It has been confirmed that BLE is the appropriate protocol to work in aviation laboratories. Proposed assembly process with additional holder make it possible to prevent all electronic components from disconnection caused by centrifugal forces and vibrations. Performed tests show operability of designed system up to 20000 rpm and correctness of preliminary design assumptions. All tests were performed in Component Test Laboratory in Łukasiewicz Research Network - Institute of Aviation where telemetry module will be used in future tests of aircraft components. Telemetry module meets all defined design assumptions, but research will be continued to find possible upgrades of the system. Future works will be focused on increasing the number of measurements channels and adaptation of rotary telemetry module for operation in the network of stationary and rotary transducers. Performed design works did not include mechanical stress analysis of telemetry module durability which should be performed before final release of a product. Outputs of this analysis should be proved during future tests of telemetry module.

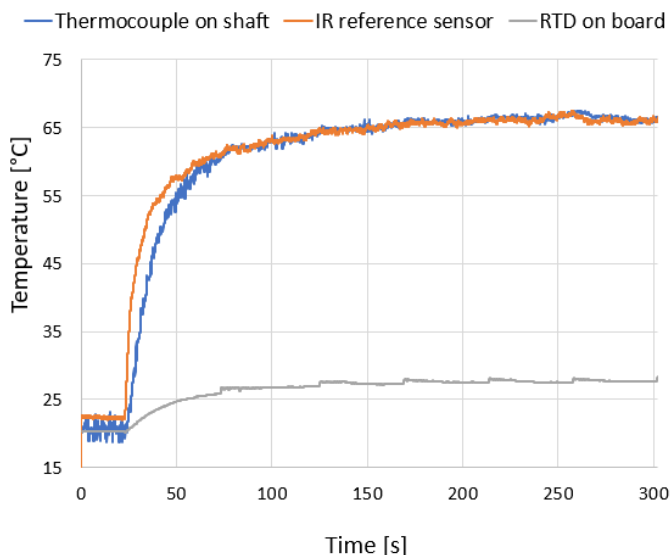

Fig. 15. Test performed at 20000 rpm

REFERENCES

- [1] L.P.Manikandan, S.S.Kulkarni, M. Radhakrishna, S. Jana, G. Gouda, N. Rajaram, A. Mahibalan, A. Kumar, V. A. Kumar "Testing of main shaft bearing of typical aero engine" Conference, Madras, Jan. 2018
- [2] X. He, W. Shu, B. Yu, X. Ma "Wireless Power Transfer System for Rotary Parts Telemetry of Gas Turbine Engine" *Electronics*, vol. 7, no. 5, April 2018 <https://doi.org/10.3390/electronics7050058>
- [3] R.G. DeAnna, "Wireless Telemetry for Gas-Turbine Applications", NASA Technical Reports Server (NTRS), pp. 2-8, March 2000
- [4] M. Imay, N. Cranley, O. Atman, "UDP based wireless telemetry network and data acquisition system for rotary application", International Telemetry Conference Proceedings, vol. 48, Arizona, October 2012
- [5] J. Wu, "A Basic Guide to Thermocouple Measurements", Texas Instruments application report, September 2018
- [6] J. Wu, "A Basic Guide to RTD Measurements", Texas Instruments application report, September 2018
- [7] W. Elmenreich, S. Pitzek "Smart Transducers - Principles, Communications, and Configuration", In Proc. of the 7th IEEE International Conference on Intelligent Engineering Systems, pp. 510-515, 2003
- [8] R. Frank, "Understanding Smart Sensors, Artech House, 3rd ed. 2013
- [9] A. Schütze, N. Helwig, T. Schneider "Sensors 4.0 – smart sensors and measurement technology enable Industry 4.0", *Journal of Sensors and Sensors Systems*, vol. 7, pp. 359–371, May 2018 <https://doi.org/10.5194/jsss-7-359-2018>
- [10] S. Sridhara, "Wireless sensor networks open new frontiers for a smarter world", Texas Instruments report, 2013
- [11] Nordic Semiconductor, "nRF52840 product specification v1.1", 2019
- [12] F. Moreno-Cruz, V. Toral-López, A. Escobar-Molero, V. U. Ruíz, A. Rivadeneyra, D. P. Morales "Ultra-Low Power Wireless Communication Protocol for IoT and Energy Harvesting", *Sensors*, vol.20 no.21, October 2020 <https://doi.org/10.3390/s20216156>
- [13] G. Kambourakis, C. Koliass, D. Geneiatakis, G. Karopoulos, G. M. Makrakis, I "A State-of-the-Art Review on the Security of Mainstream IoT Wireless PAN Protocol Stacks", *Symmetry*, vol. 12, no. 4, April 2020 <https://doi.org/10.3390/sym12040579>
- [14] M. Woolley, "Bluetooth Core Specification Version 5.2 Feature Overview", December 2020
- [15] C. Gomez, J. Oller, J. Paradells, "Overview and Evaluation of Bluetooth Low Energy: An Emerging Low-Power Wireless Technology", *Sensors*, vol.12, no.9, August 2012 <https://doi.org/10.3390/s120911734>
- [16] A. Dementyev, S. Hodges, S. Taylor, J. Smith, "Power Consumption Analysis of Bluetooth Low Energy, ZigBee and ANT Sensor Nodes in a Cyclic Sleep Scenario", Proceedings of the 2013 IEEE International Wireless Symposium (IWS); Beijing, China, April 2013; <https://doi.org/10.1109/IWS.2013.6616827>
- [17] J. Fraden, "Handbook of Modern Sensors – Physics, Design, and Applications", Springer, 4th ed., 2010, pp. 196-197 <https://doi.org/10.1007/978-1-4419-6466-3>
- [18] Maxim Integrated, MAX11410 product specification, 2019
- [19] Maxim Integrated, MAX6029 product specification, 2009
- [20] Naoki Shinohara, "History and Innovation of Wireless Power Transfer via Microwaves", *IEEE Journal of Microwaves*, vol. 1, no. 1, pp. 218-228, Jan. 2021, <https://doi.org/10.1109/JMW.2020.3030896>
- [21] "System Reference document (SRdoc) - Wireless Power Transmission (WPT) systems operating below 30 MHz", 2019
- [22] Wireless Power Consortium, "Introduction to the Power Class 0 Specification", Technical specification, Feb. 2017
- [23] AirFuel Alliance, "AirFuel Alliance Resonant Wireless Power Transfer (WPT) System Baseline System Specification (BSS)", July 2018
- [24] Nordic Semiconductor Software Development Kit documentation